

**DORIAN**  
INTERNATIONAL  
**TOOL**

*The First Choice*  
TECHNOLOGY

# Jet-Stream™

Thru Coolant Cutting Tools

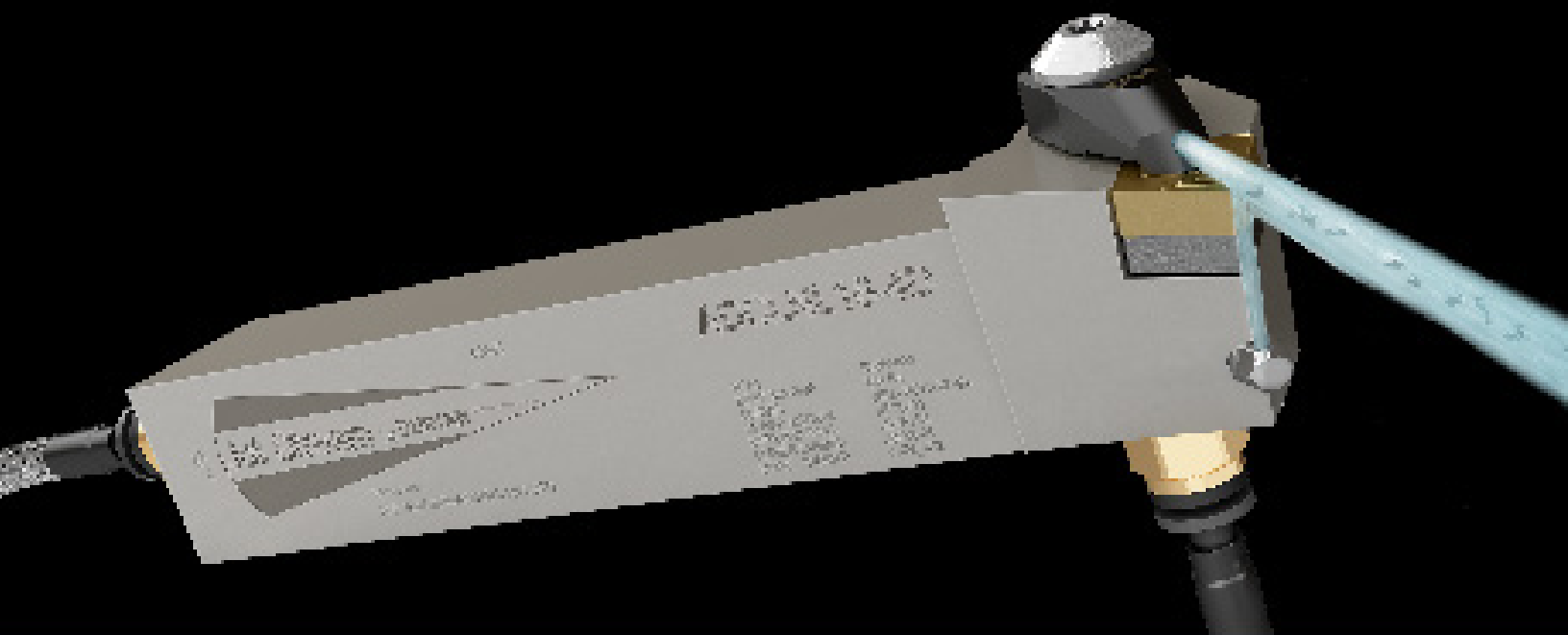

Changing The Way Metal is Cut!

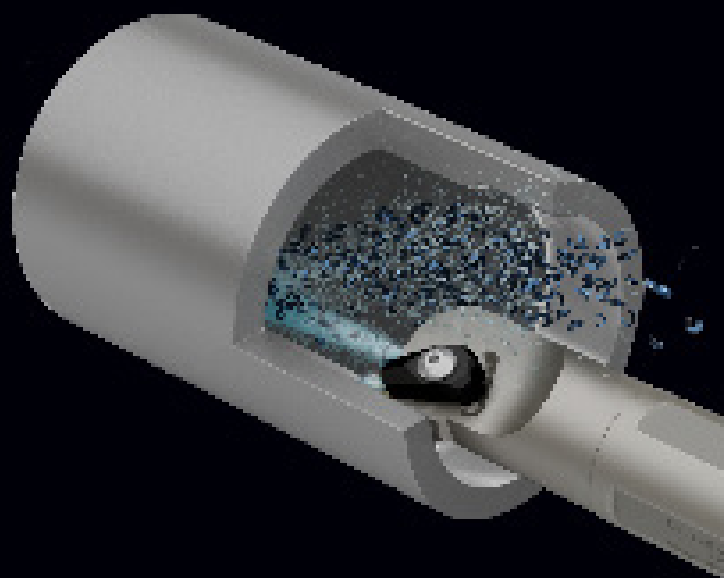

Best of 2015 Indexable Cutting Tools

# Jet-Stream™ Thru Coolant System

ADCLN R/L Toolholder  
for negative  
80° diamond  
CNM\_inserts



Inch B-14 / Metric B-34

ADDJN R/L Toolholder  
for negative  
55° diamond  
DNM\_inserts



Inch B-14 / Metric B-34

ADDPNN Toolholder  
for negative  
55° diamond  
DNM\_inserts

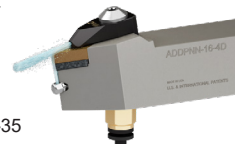

Inch B-15 / Metric B-35

ADSDNN Toolholder  
for negative  
square  
SNM\_inserts



Inch B-15 / Metric B-35

ADSRN R/L Toolholder  
for negative  
square  
SNM\_inserts



Inch B-16 / Metric B-36

ADTENN Toolholder  
for negative  
triangle  
TNM\_inserts

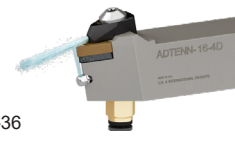

Inch B-16 / Metric B-36

ADTJN R/L Toolholder  
for negative  
triangle  
TNM\_inserts



Inch B-17 / Metric B-37

ADVJN R/L Toolholder  
for negative 35°  
diamond  
VNM\_inserts



Inch B-17 / Metric B-37

ADWLN R/L Toolholder  
for negative  
80° trigon  
WNM\_inserts



Inch B-18 / Metric B-38

AS-ADCLN R/L Bar  
for negative  
80° diamond  
CNM\_inserts

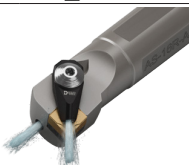

Inch B-20 / Metric B-38

AS-ADTUN R/L Bar  
for negative  
triangle  
TNM\_inserts



Inch B-20 / Metric B-40

AS-ADDUN R/L Bar  
for negative  
55° diamond  
DNM\_inserts



Inch B-21 / Metric B-39

AS-ADDPN R/L Bar  
for negative  
55° diamond  
DNM\_inserts



Inch B-21 / Metric B-39

AS-ADSKN R/L Bar  
for negative  
square  
SNM\_inserts



Inch B-22 / Metric B-40

AS-ADVUN R/L Bar  
for negative  
35° diamond  
VNM\_inserts



Inch B-22 / Metric B-41

AS-ADWLN R/L Bar  
for negative  
80° trigon  
WNM\_inserts



Inch B-23 / Metric B-41

ADTVO R Toolholder  
for OnEdge  
threading triangle  
TNMC inserts



Inch B-27

AS-ADTHO R/L Bar  
for OnEdge  
threading triangle  
TNMC inserts

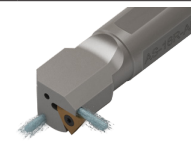

Inch B-27

ADNS R/L Toolholder  
for threading  
and grooving  
DorNotch inserts



Inch B-29

ADNE R/L Toolholder  
for threading  
and grooving  
DorNotch inserts



Inch B-29

AS-ADNE R/L Bar  
for threading  
and grooving  
DorNotch inserts

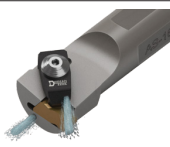

Inch B-30

ADLE R/L Toolholder  
for threading  
Laydown inserts

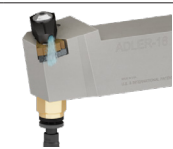

Inch Page B-32

ADLE R/L Qualified  
Toolholder for threading  
Laydown inserts

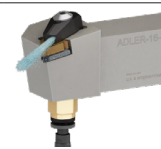

Inch B-32 / Metric B-42

AS-ADLN R/L Bar  
for Laydown  
threading inserts



Inch B-33 / Metric B-42

ADLE API Qualified  
Toolholder for threading  
Laydown inserts



Inch B-44 / Metric B-48

AS-ADLN API Bar  
for Laydown  
threading inserts

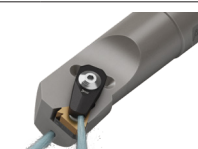

Inch B-44 / Metric B-48

ADLE R/L API Toolholder  
for API Laydown  
threading inserts



Inch B-45

AS-ADLN R/L API Bar  
for API Laydown  
threading inserts



Inch B-45

AS-ADTHO API Bar  
for OnEdge threading  
triangle TNMC inserts

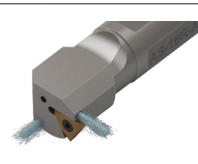

Inch B-46

ADNS API Toolholder  
for threading & grooving  
DorNotch inserts

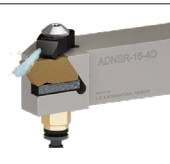

Inch B-46

AS-ADNE API Bar  
for threading & grooving  
DorNotch inserts



Inch B-47

Jet-Stream™  
Thru Coolant  
Connector Kits  
and Coolant  
Nozzels

Page B-49



One standard coolant connector kit with 12" tubing is supplied



Jet-Stream™  
Thru Coolant  
Spare Parts

Page B-50

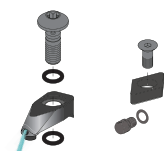

# Heat and Machining!

**Heat that is allowed to accumulate can be very detrimental to tooling**, as well as to the surface of the work piece. The nice blue color in a chip means that the metal has seen very high temperatures. Most steels need to get to a temperature of at least 800° F to acquire an obvious blue oxide surface and the temperature at the tip of the cutting tool can often be over twice as hot. At these temperatures coolant is completely vaporized before it can reach the cutting zone.

**Heat can be removed** by simply pouring the coolant over the tool as it cuts. This is referred to as 'FLOOD' cooling, and has been the standard method for years. The coolant picks up heat as it washes over the area. A problem is that, even with the best operators, the coolant line is rarely aimed at the critical point. Even with the most careful coolant application, however, at the high performance levels available with modern machine tools, so much heat is generated that the coolant is heated to beyond its boiling point. A blanket of vapor forms over the very area we're trying to cool, insulating it from the coolant. The only way heat can be drawn out of the area is by radiating it through the vapor blanket, and by conduction back through the tool. Either way, only a fraction of the heat-carrying capacity of the coolant is being used.

**With standard turning tools** the coolant doesn't even hit the part. The operator aims the coolant by hand at the tool using snap together plastic beads or copper tubing. Every operator does it differently, and during operation the coolant lines are frequently pushed out of alignment so that the operator has to manually readjust the aim of the coolant, often every time they change a part. One coolant manufacturer estimates that 40% of the time the coolant doesn't hit the tool or the part. Even when the coolant hits the tool there is no directional control; it can typically come from any direction within a 180-degree arc in one axis and a 90-degree arc in the other axis. Real process control from setup to setup and throughout a production run is virtually nonexistent.

**Coolant alignment** machined into the Jet-Stream™ Tool Holder: Dorian has introduced a patented through coolant clamping system as part of the holder, insuring that the coolant always hits the insert at exactly the right spot, putting the force where you need it. The process is repeatable from setup to setup and throughout a production run.

**The coolant that is aimed at the tool** doesn't get to the tip of the tool: The essence of the problem with standard low pressure coolant systems is that so much heat is produced that the coolant boils away before it can reach the chip tool interface where metal is actually cut. The super heated steam forms a barrier that low pressure coolant can't penetrate. Effective cooling does not occur and there is little real lubrication provided. Unfortunately, the vapor barrier that forms is not powerful enough to keep chips from falling back into the chip/tool interface and causing damage.

**High pressure cooling in conjunction with the Dorian High Volume Jet-Stream™ System**, allows the coolant to be introduced in such a way as to remove the heat at a high enough rate and pressure to eliminate the vapor barrier. This allows a direct heat transfer from the mass of the insert to the mass of the coolant. The temperature of the tool, in some cases, is only slightly above the temperature of the coolant.

**Dorian Jet-Stream™ Tooling** uses a patented coolant through locking clamp which is precisely aimed to insert high pressure, high velocity coolant into exactly the spot where the heat is generated.

## Good

Coolant flows with no control and low pressure, losing efficiency and proper cooling effect on the insert.

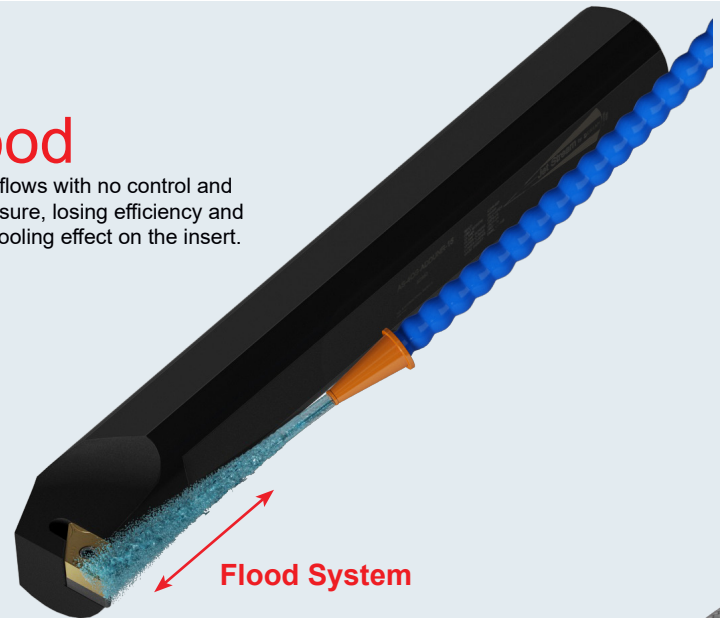

## Better

The coolant aim has improved control, but the pressure dissipates because of the extended distance between the insert edge and where the coolant is released.



## Best

At a close range of 1/4" (6mm), the coolant is aimed precisely onto the cutting edge of the insert at a very high velocity, keeping a clean insert surface and a constant working temperature.







# Before

---

## Jet-Stream™ Application

Hot chips do not break away from the insert cutting edge.





# After

---

## Jet-Stream™ Application

**Hot Chips are Forced Away from the insert cutting edge.**  
As a result, the insert will operate at a constant low temperature,  
with a clean and undamaged cutting edge,  
**changing the way metal is cut!**

At a close range of 1/4" (6mm)  
the Jet-Stream™ Coolant System aims the coolant precisely  
onto the cutting edge of the insert at a very high velocity.

**Longer Insert Life, Better Surface Finish and Higher Speeds and Feeds!**

The patented Jet-Stream™ system is designed for use in all turning, boring and threading applications from heavy roughing to high-speed finishing and threading.

The Jet-Stream™ High Pressure Application **Forces the Hot Chips to Hydroplane** away from the cutting edge of the insert, keeping a clean insert surface and a constant working temperature.

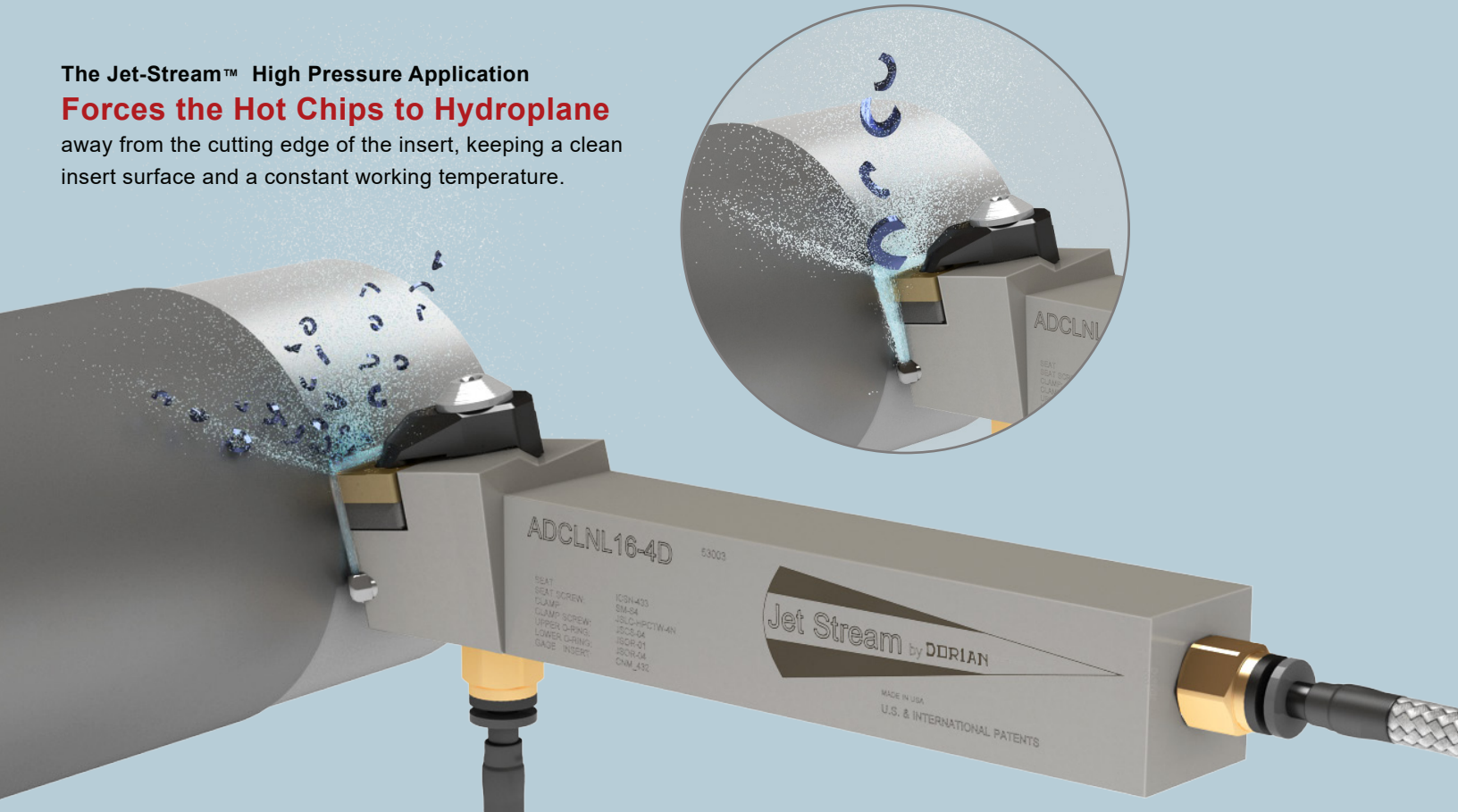

Double Jet Coolant Outlet Thru Coolant Dor-Lock™ Clamp shoots coolant directly over the cutting edge of the insert.

Powerful Thru Coolant Dor-Lock Clamping System Lock and release the insert quickly and powerfully with the new patented Dor-Lock clamping system.

Chromium-Molybdenum Alloy Seel Body high tensile strength and high yield stress. This material is heat treated to 40-44Rc and Electroless Nickel Coated. Electroless Nickel Coating will prevent the tools against rust providing a long tool life under severe working conditions.

**Patented thru coolant and locking clamp in one system.**

Double Jet Coolant Outlet Coolant shoots directly over the workpiece as well as the insert shown above.

Double 1/8 NPT Coolant Inlet simplifies the coolant connection to the machine.



**The patented Dor-Lock™ clamping system Locks the insert securely down**  
and aims the coolant flow precisely over the cutting edge of the insert  
**All Jet-Stream™ toolholders and boring bars use industry standard inserts**  
and are available in multiple geometries.

**The Jet-Stream™ Blind Boring Application**  
**Helps prevent damage to the insert,**  
the tool itself and even the part that is being cut.

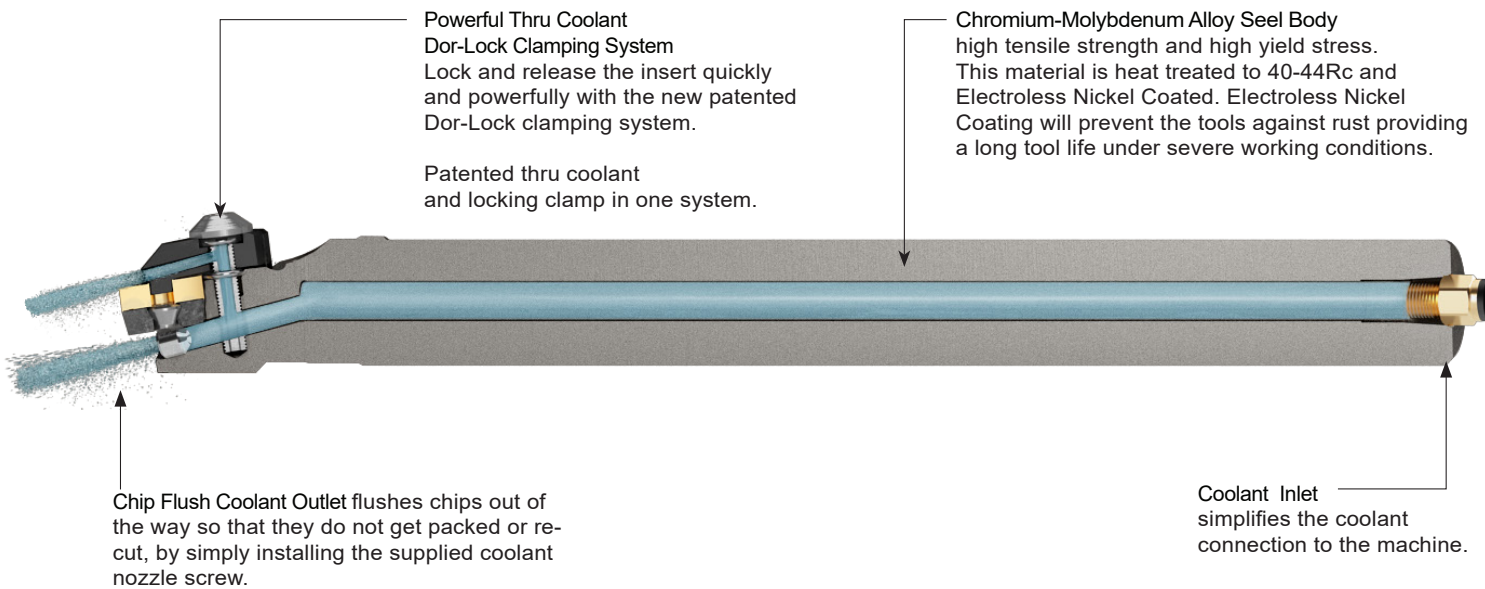
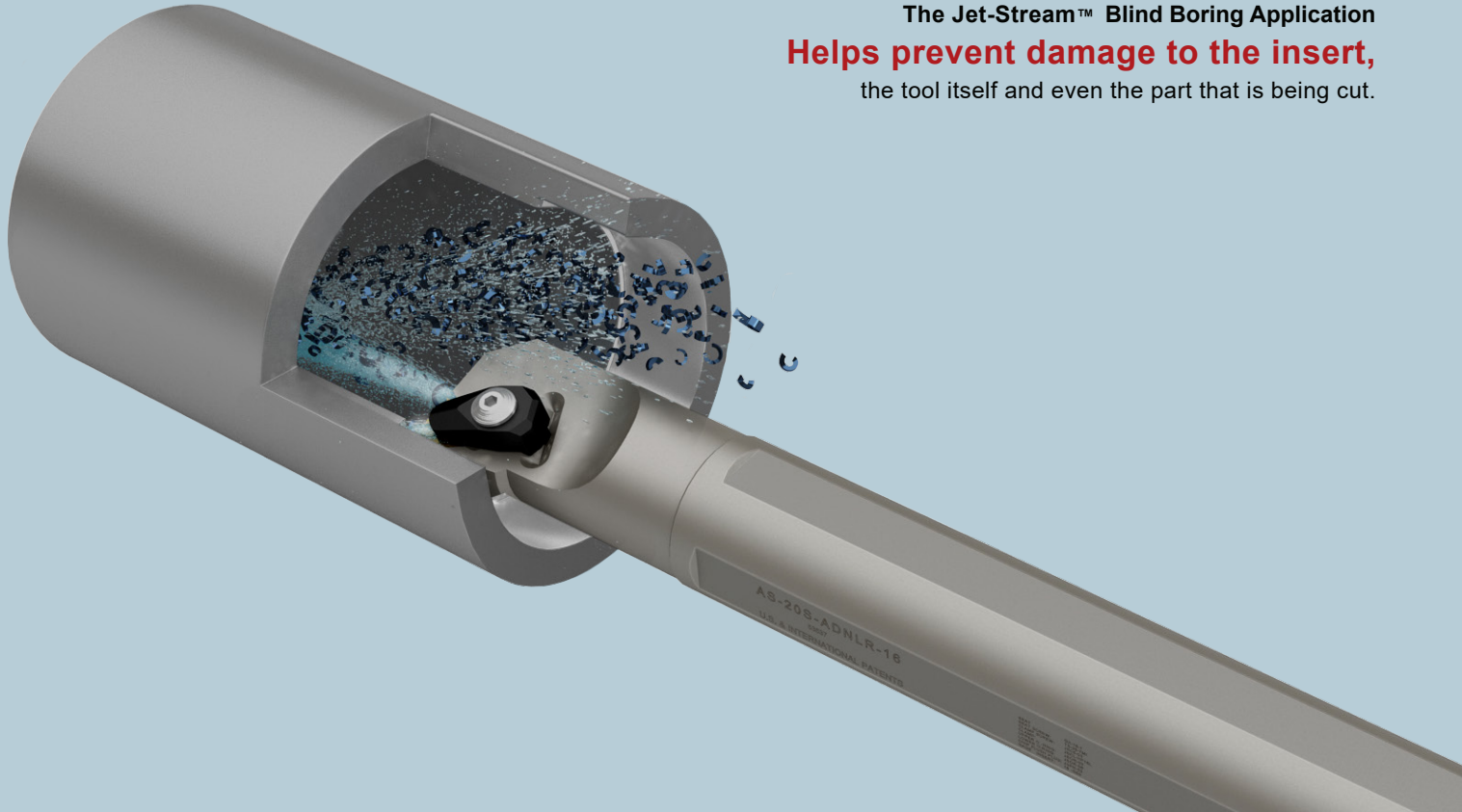





## Patented Thru Coolant Dor-Lock™ Clamp 70 - 1400 psi (5 -100 Bar)

- Extreme Lubrication at the cutting edge
- Extreme Heat Dissipation at the cutting edge
- Constant Low Cutting Edge Temperature
- Greater Chip Control and Evacuation
- Chip Breaking at High Pressures
- Smooth Cutting Action and Surface Finish
- Increased Speeds and Feeds

Supplied Standard with all Jet-Stream™ Tools  
Thru Coolant Dor-Lock™ Clamp Style JSLC-HP  
Operates at a Maximum of 1400 psi (100 Bar)

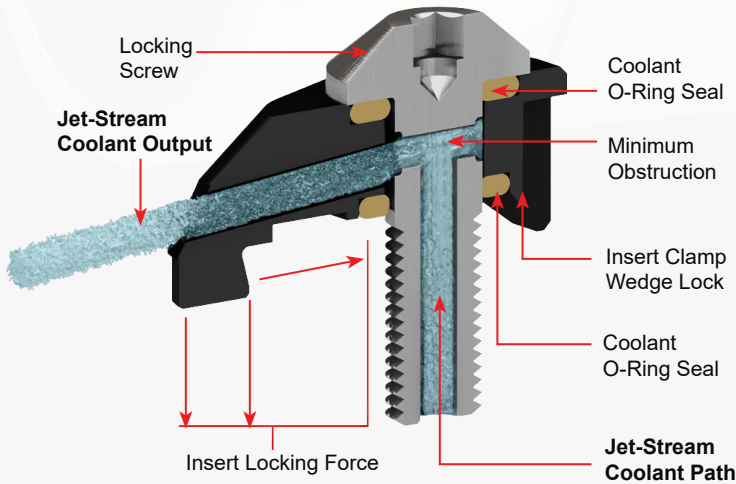

- Locks and cools the insert in one action
- Aimes the coolant to the cutting edge
- Aimes the coolant underneath the chip

Sold Separately to Deliver High Coolant Volume  
for Applications above 1000 psi  
High Volume Thru Coolant Dor-Lock™ Clamp Style JSLC-HPV  
Operates at a Maximum of 1400 psi (100 Bar)

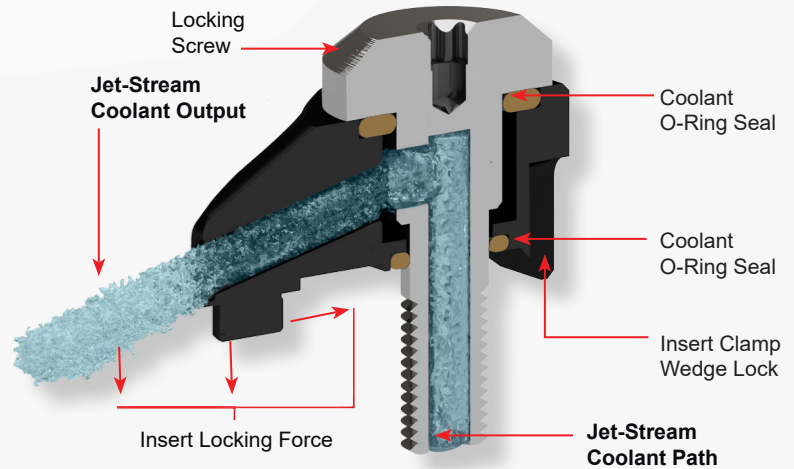

Maximum performance will be achieved  
at 1000 psi and above with a coolant volume of ½ gpm  
(gallon per minute) per machine horsepower.

### Improved Productivity (70 psi):

The **Jet-Stream™** Thru Coolant System will immediately improve machine performance with higher sfm (surface footage), extended tool life, ability to hold closer tolerances, and improvement of surface finish. The **Jet-Stream™** tooling will excel because it makes machining simple and easy for materials ranging from low carbon steel to high temper alloys, exotics and aerospace materials.

### How to Optimize Productivity (1000 psi)

A minimum of 70 psi / 5 Bar is required for the **Jet-Stream™** to show improvements in machining performance. To reach optimum results, higher coolant pressure and volume are necessary. Maximum performance will be achieved at 1000 psi and above with a coolant volume of ½ gpm (gallon per minute) per machine horsepower. Example: A 15 HP machine will need a coolant pump of 1000 psi with 7.5 gpm of coolant volume.

# The Jet-Stream™ High force coolant breaks chips and keeps them away from the tool.

**High force coolant (pressure and volume) prevents Vapor Barrier:** Properly applied high pressure and high volume coolant prevents this vapor barrier from forming by removing the energy created in the turning process and creating a region of high pressure which raises the boiling point of the coolant. So much liquid is forced into the cutting zone that heat is removed and no vapor can form because of the pressurization. A great deal of **FORCE** is required to achieve this pressurization. This liquid has the added benefit of providing lubrication and flushes chips away from the cut. There is a great deal of discussion about pressure, pressure is meaningless without volume.

**Force requires both mass and velocity, and the coolant must, of course, be focused at the chip tool interface.**

**It doesn't matter how big a gun you have if you miss the target.**

**When you combine the Dorian Jet-Stream™ tools with a high pressure pump you gain real control of your process, damage from heat and chips is eliminated and tools can cut until they wear out.** Controlled high-pressure coolant keeps the temperature low; changing the way metal is cut. Tools last longer, chips can't weld to the insert and metal can be cut at much higher surface speeds than ever before. Dangerous decomposition of the chemicals mixed in coolants do not occur at low temperatures. Combining a properly designed high pressure and high volume pumping system and the Dorian Jet Stream tooling system allows surface speed to be increased a minimum of 30%, with some operations improving by 300%. High-pressure coolant also provides lubricity by blasting lubricating fluid between the chip and the insert and hundreds of miles per hour. This increased lubricity combined with much lower temperature and the ejection of cut material often causes surface finishes to have a RMA twice as good as can be achieved by traditional methods.

**Chip damage from long stringy chips:** Chips cause unpredictable damage. In general, the longer the chips, the harder it is to control and the more damage they cause. Long stringy chips wrap around boring bars, fill the bottoms of holes, catch on the chucks, cause mechanical problems with loaders, and in many cases require manual removal. All of these slow down the production process and eat away at your profitability. Broken chips that can fall away, or that can be blown out of the cutting zone with coolant force and away from the part and tool are always more desirable. Many people don't understand the difference between wear and damage. Wear is a predictable part of any mechanical process. Damage, on the other hand, is random, producing the same bell shaped curve that any random event with enough samples must produce. When inserts wear out you can control your production process, when they fail you can not.

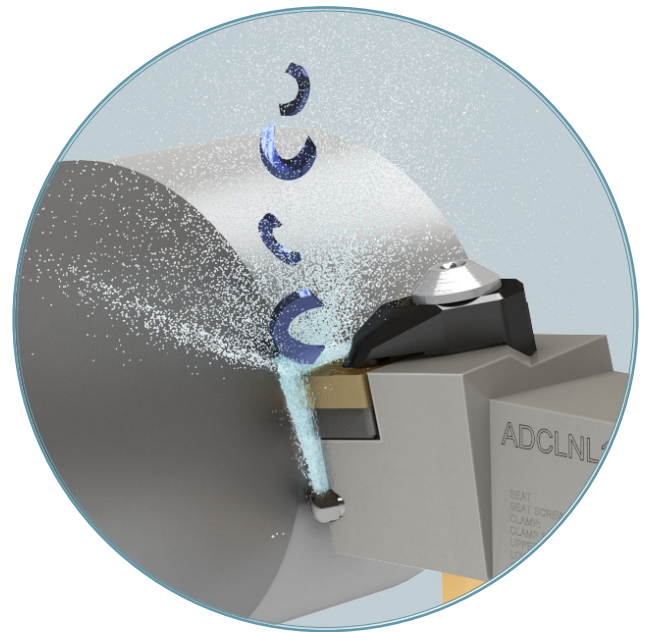

## Short chips with high pressure

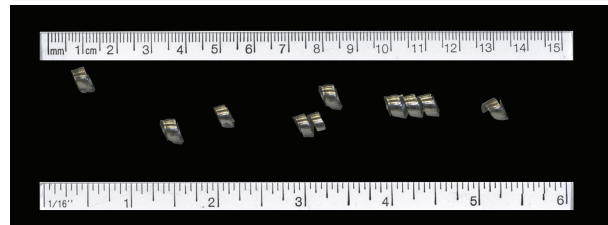

## High Pressure

High Pressure and volume directed into the chip-tool interface never lets the temperature get out of control. The shear zone is short and the chips break over the base material. The part itself is acting as a chip breaker.

## Long chips made with low pressure

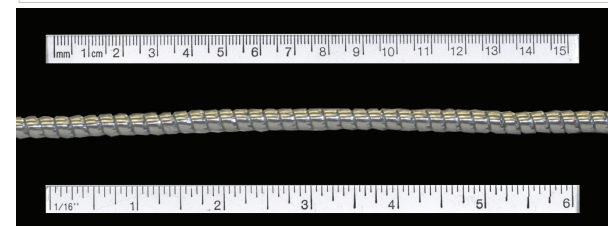

## Standard Pressure

Low-pressure coolant allows a long shear zone that does not break chips in many materials. The result is long uncontrollable chips.

70 - 1400 psi (5 -100 Bar)

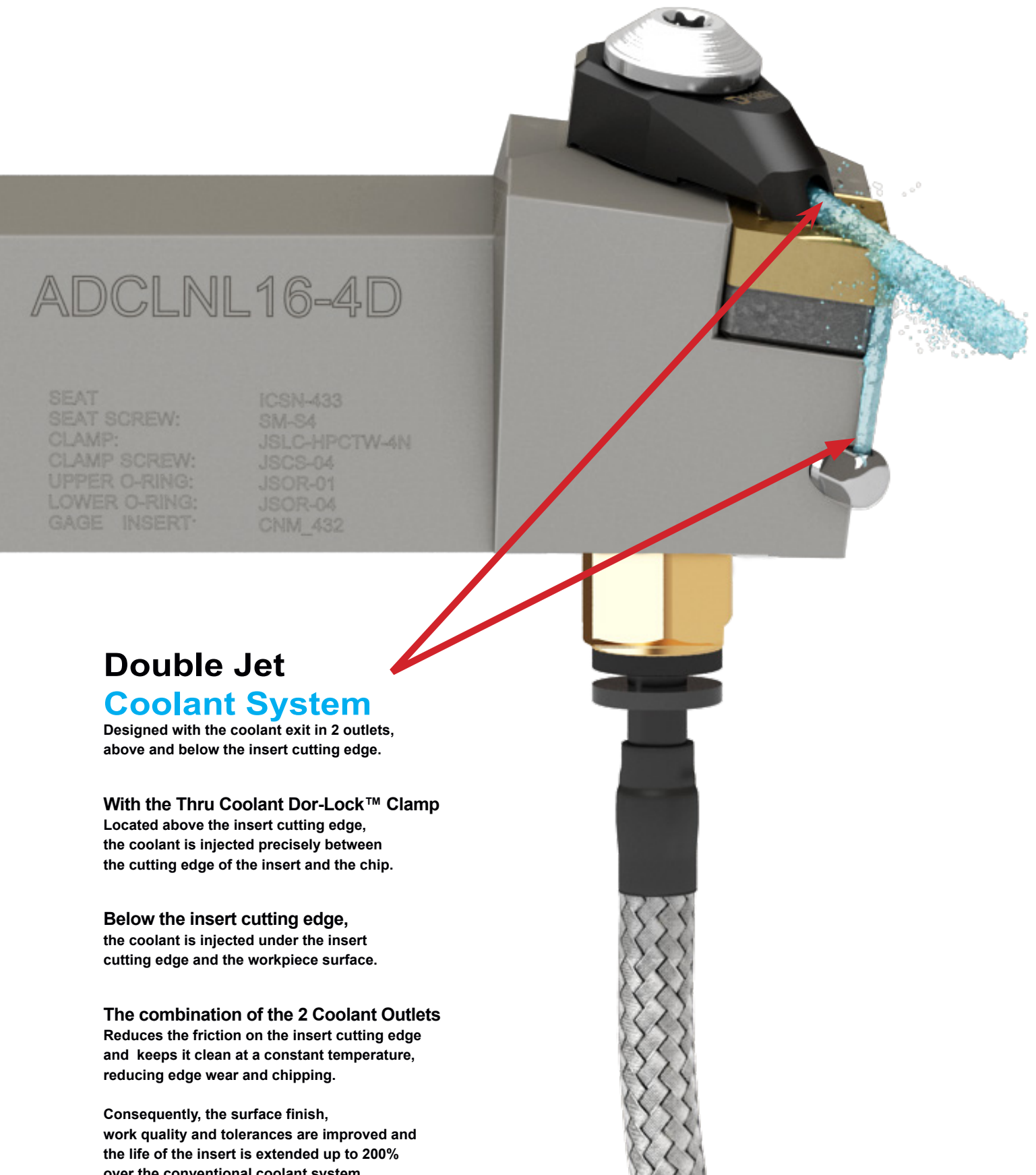

ADCLNL16-4D

SEAT	ICSN-433
SEAT SCREW:	SM-S4
CLAMP:	JSLC-HPCTW-4N
CLAMP SCREW:	JSCS-04
UPPER O-RING:	JSOR-01
LOWER O-RING:	JSOR-04
GAGE INSERT:	CNM_432

## Double Jet Coolant System

Designed with the coolant exit in 2 outlets,  
above and below the insert cutting edge.

### With the Thru Coolant Dor-Lock™ Clamp

Located above the insert cutting edge,  
the coolant is injected precisely between  
the cutting edge of the insert and the chip.

Below the insert cutting edge,  
the coolant is injected under the insert  
cutting edge and the workpiece surface.

### The combination of the 2 Coolant Outlets

Reduces the friction on the insert cutting edge  
and keeps it clean at a constant temperature,  
reducing edge wear and chipping.

Consequently, the surface finish,  
work quality and tolerances are improved and  
the life of the insert is extended up to 200%  
over the conventional coolant system.



70 - 1400 psi (5 -100 Bar)

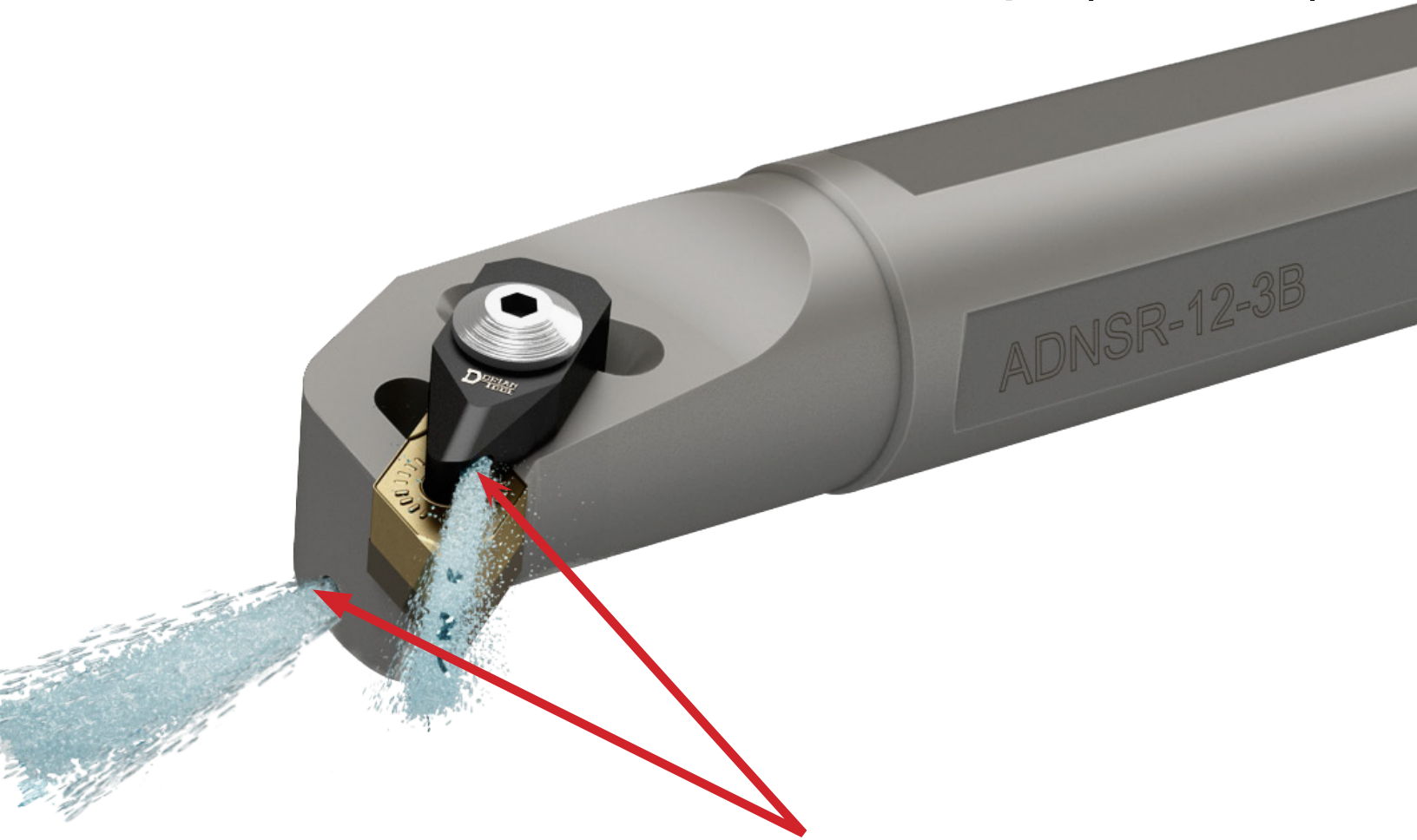

## Double Jet Coolant System

Designed with the coolant exit in 2 outlets,  
above and below the insert cutting edge.

### With the Thru Coolant Dor-Lock™ Clamp

Located above the insert cutting edge,  
the coolant is injected precisely between  
the cutting edge of the insert and the chip.

### The Chip Flush Coolant Outlet

Located below the insert on the front  
of the bar , flushes chips out of the way  
so that they do not get packed  
or re-cut, by simply installing  
the supplied coolant nozzle screw.











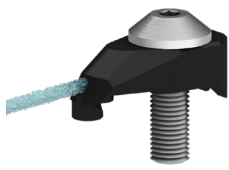

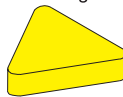
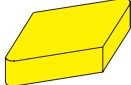

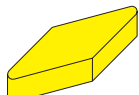

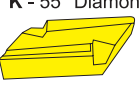

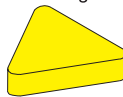
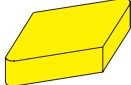

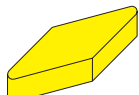

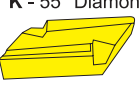











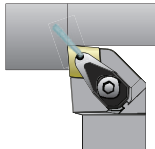
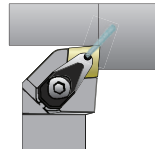
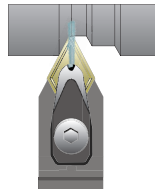
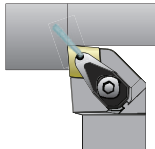
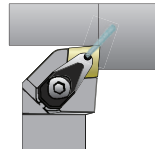
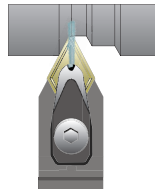

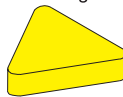
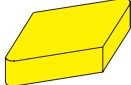
### The combination of the 2 Coolant Outlets

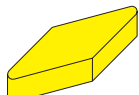
Reduces the friction on the insert cutting edge  
and keeps it clean at a constant temperature,  
reducing edge wear and chipping.

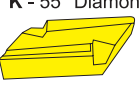
A.N.S.I. (American National Standards Institute)  
ADCLNR-16-4D

I.S.O. (International Standards Organization)  
ADCLNR-2020-K12

# Turning Identification System

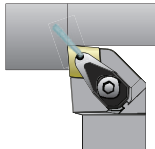
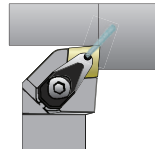
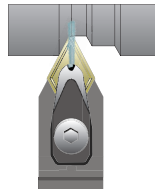



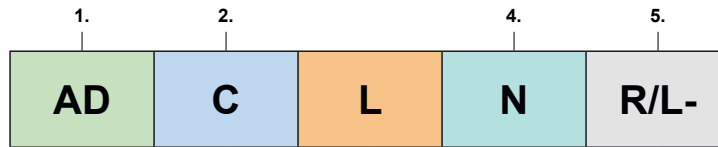



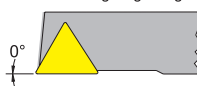
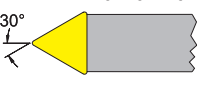
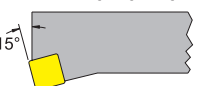
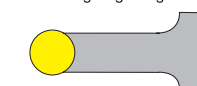

<p><b>AD - Thru Coolant Dor-Lock Clamp</b></p> 	<table border="0"> <tr> <td><b>C - 80° Diamond</b> </td> <td><b>T - Triangle</b> </td> </tr> <tr> <td><b>D - 55° Diamond</b> </td> <td><b>W - 80° Trigon</b> </td> </tr> <tr> <td><b>R - Round</b> </td> <td><b>V - 35° Diamond</b> </td> </tr> <tr> <td><b>S - Square</b> </td> <td><b>K - 55° Diamond</b> </td> </tr> </table>	<b>C - 80° Diamond</b> 	<b>T - Triangle</b> 	<b>D - 55° Diamond</b> 	<b>W - 80° Trigon</b> 	<b>R - Round</b> 	<b>V - 35° Diamond</b> 	<b>S - Square</b> 	<b>K - 55° Diamond</b> 	<table border="0"> <tr> <td><b>B - 5° Positive</b> </td> </tr> <tr> <td><b>C - 7° Positive</b> </td> </tr> <tr> <td><b>D - 15° Positive</b> </td> </tr> <tr> <td><b>E - 20° Positive</b> </td> </tr> <tr> <td><b>N - 0° Negative</b> </td> </tr> <tr> <td><b>P - 11° Positive</b> </td> </tr> </table>	<b>B - 5° Positive</b> 	<b>C - 7° Positive</b> 	<b>D - 15° Positive</b> 	<b>E - 20° Positive</b> 	<b>N - 0° Negative</b> 	<b>P - 11° Positive</b> 	<table border="0"> <tr> <td><b>R - Right Hand</b> </td> </tr> <tr> <td><b>L - Left Hand</b> </td> </tr> <tr> <td><b>N - Neutral</b> </td> </tr> </table>	<b>R - Right Hand</b> 	<b>L - Left Hand</b> 	<b>N - Neutral</b> 
<b>C - 80° Diamond</b> 	<b>T - Triangle</b> 																			
<b>D - 55° Diamond</b> 	<b>W - 80° Trigon</b> 																			
<b>R - Round</b> 	<b>V - 35° Diamond</b> 																			
<b>S - Square</b> 	<b>K - 55° Diamond</b> 																			
<b>B - 5° Positive</b> 																				
<b>C - 7° Positive</b> 																				
<b>D - 15° Positive</b> 																				
<b>E - 20° Positive</b> 																				
<b>N - 0° Negative</b> 																				
<b>P - 11° Positive</b> 																				
<b>R - Right Hand</b> 																				
<b>L - Left Hand</b> 																				
<b>N - Neutral</b> 																				

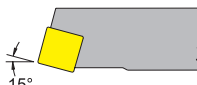
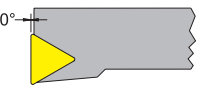
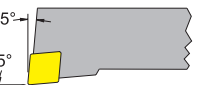
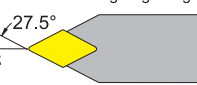
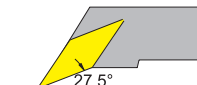
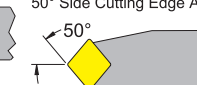
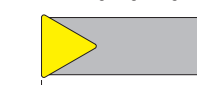
1. Clamp Style	2. Insert Shape	4. Insert Clearance Angle	5. Hand of Tool
----------------	-----------------	---------------------------	-----------------

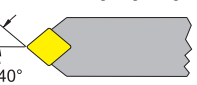

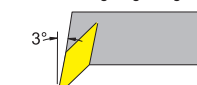
3.

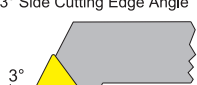
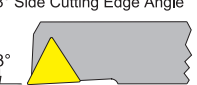
## 3. Tool Style

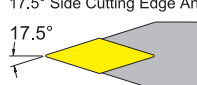
<b>A - Straight Shank</b> 0° Side Cutting Edge Angle 	<b>E - Straight Shank</b> 30° Side Cutting Edge Angle 	<b>K - Offset Shank</b> 15° End Cutting Edge Angle 	<b>O - Straight Shank</b> Round Cutting Edge Angle 	<b>S - Offset Shank</b> 45° Side Cutting Edge Angle 	<b>W - Offset Shank</b> 10° Side Cutting Edge Angle 
<b>B - Straight Shank</b> 15° Side Cutting Edge Angle 	<b>F - Offset Shank</b> 0° End Cutting Edge Angle 	<b>L - Offset Shank</b> 5° Edge Angle 	<b>P - Straight Shank</b> 27.5° Side Cutting Edge Angle 	<b>T - Offset Shank</b> 27.5° Side Cutting Edge Angle 	<b>Y - Straight Shank</b> 50° Side Cutting Edge Angle 
<b>C - Straight Shank</b> 0° End Cutting Edge Angle 	<b>G - Offset Shank</b> 0° Side Cutting Edge Angle 	<b>M - Straight Shank</b> 40° Side Cutting Edge Angle 	<b>Q - Offset Shank</b> Convex Radius Cutting Edge 	<b>U - Offset Shank</b> 3° End Cutting Edge Angle 	<b>R - Offset Shank</b> 15° Side Cutting Edge Angle 
<b>D - Straight Shank</b> 45° Side Cutting Edge Angle 	<b>J - Offset Shank</b> 3° Side Cutting Edge Angle 	<b>N - Straight Shank</b> 3° Side Cutting Edge Angle 	<b>R - Offset Shank</b> 15° Side Cutting Edge Angle 	<b>V - Straight Shank</b> 17.5° Side Cutting Edge Angle 	

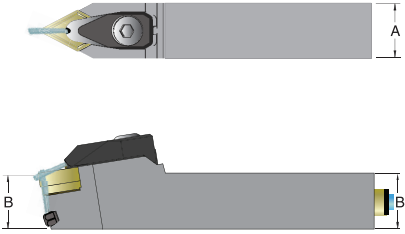
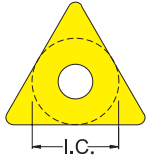
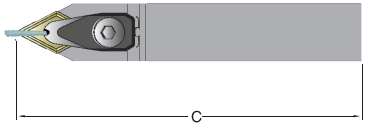
 <p>(A) &amp; (B) shown in 1/16" increments EX: 16 units (16 x 1/16") = 1" square</p>	 <p>Shown in 1/8" increments Insert Size I.C.</p>	 <p>J - 3.5" A - 4.0" B - 4.5" C - 5.0" D - 6.0" E - 7.0" F - 8.0"</p>
--	--	---

6. Shank Size	7. Insert Size I.C.	8. Tool Length
---------------	---------------------	----------------



6.	7.	8.
<b>16</b>	<b>4</b>	<b>D</b>
<b>2020</b>	<b>12</b>	<b>K</b>
6.	7.	8.

6. Shank Size	7. Insert length	8. Tool Length
---------------	------------------	----------------

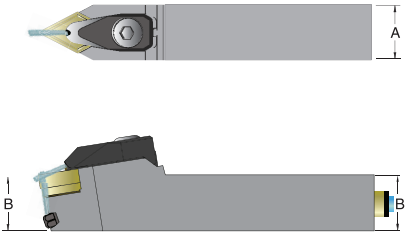
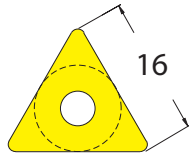
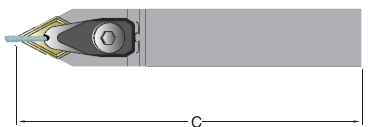
<p>(A) &amp; (B) shown in 1mm increments EX: 2525 = 25mm square</p> 	<p>Shown in 1mm increments</p> 	<p>D - 60 mm E - 70 mm F - 80 mm H - 100 mm K - 125 mm M - 150 mm P - 170 mm S - 250 mm</p> 
---	--	---



**ADCLN R/L Toolholder Style L - 5° end or side cutting lead angle for negative 80° diamond CNM\_inserts**

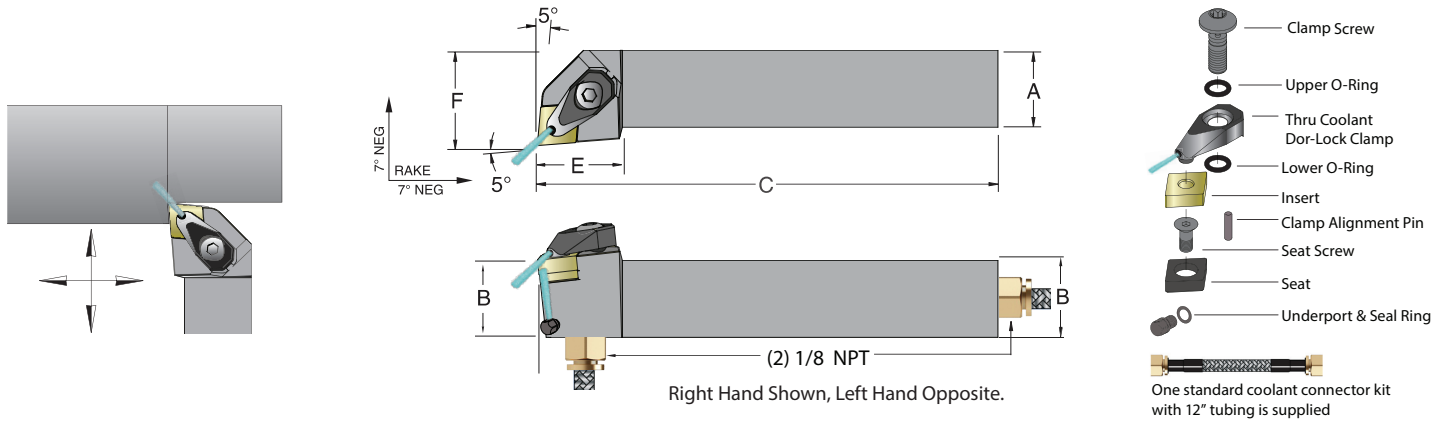

Inch Description	UPC No. 733101-		A	B	C	E	F	CNM_ Gage Insert	Seat	Seat Screw	Dor-Lock Clamp	Clamp Screw	Upper 'O' Ring	Lower 'O' Ring
	R.H.	L.H.												
ADCLNR/L-12-4B	53000	53001	0.75	0.75	4.50	1.250	1.000	432	JC-432	SM-S4	JSLC-HPCTW-4N	JSCS-04	JSOR-01	JSOR-04
ADCLNR/L-16-4D	53002	53003	1.00	1.00	6.00	1.250	1.250	432	JC-432	SM-S4	JSLC-HPCTW-4N	JSCS-04	JSOR-01	JSOR-04
ADCLNR/L-16-5D	53105	53106	1.00	1.00	6.00	1.375	1.250	543	JC-533	SM-M6	JSLC-HPC5	JSCS-04	JSOR-01	JSOR-04
ADCLNR/L-20-4D	53004	53005	1.25	1.25	6.00	1.250	1.500	432	JC-432	SM-S4	JSLC-HPCTW-4N	JSCS-04	JSOR-01	JSOR-04
ADCLNR/L-20-5D	53006	53007	1.25	1.25	6.00	1.375	2.000	543	JC-533	SM-M6	JSLC-HPC5	JSCS-04	JSOR-01	JSOR-04
ADCLNR/L-20-6E	53012	-	1.25	1.25	7.00	1.500	1.500	643	JC-633	SM-M6	JSLC-HPC6	JSCS-06	JSOR-01	JSOR-202
*ADCLNR/L-24-4E	53008	53009	1.50	1.50	7.00	1.250	2.000	432	JC-432	SM-S4	JSLC-HPCTW-4N	JSCS-04	JSOR-01	JSOR-04
*ADCLNR/L-24-5E	53010	53011	1.50	1.50	7.00	1.375	2.000	543	JC-533	SM-M6	JSLC-HPC5	JSCS-04	JSOR-01	JSOR-04
*ADCLNR/L-24-6E	53014	53015	1.50	1.50	7.00	1.500	2.000	643	JC-633	SM-M6	JSLC-HPC6	JSCS-06	JSOR-01	JSOR-202

\*Special Order, available upon request. One standard coolant connector kit with tubing is supplied, see page B-49 for details and high pressure coolant fitting. For Turning inserts see Sect.A. For spare parts see page B-50.

**ADDJN R/L Toolholder Style J - 3° side cutting lead angle for negative 55° diamond DNM\_inserts**

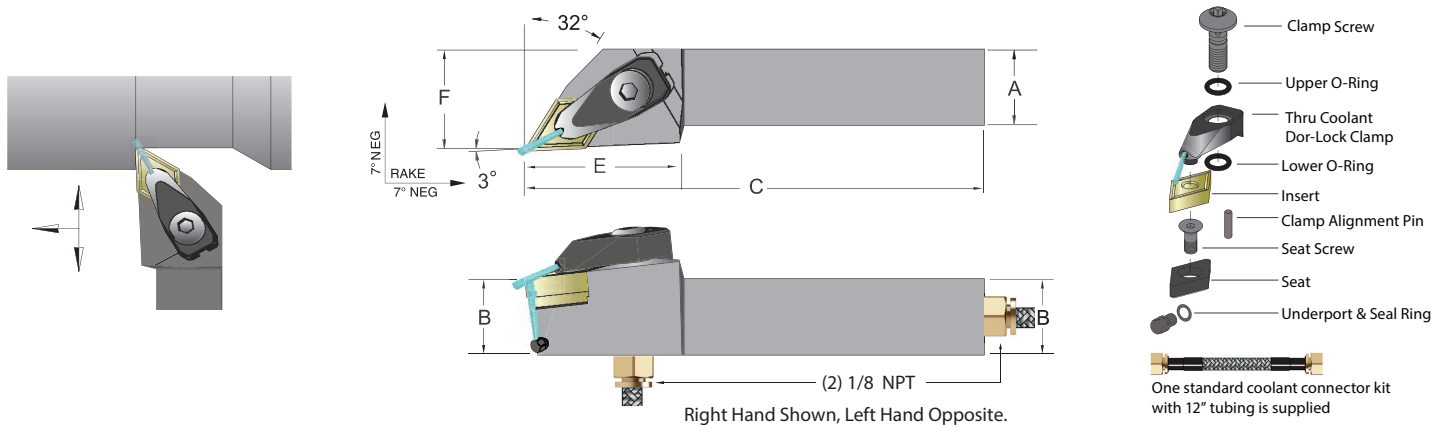

Inch Description	UPC No. 733101-		A	B	C	E	F	DNM_ Gage Insert	Seat	Seat Screw	Dor-Lock Clamp	Clamp Screw	Upper 'O' Ring	Lower 'O' Ring
	R.H.	L.H.												
ADDJNR/L-12-3B	53016	53017	0.75	0.75	4.50	1.500	1.000	332	IDSN-322	SM-M4-245	JSLC-HPD3	JSCS-04	JSOR-01	JSOR-04
ADDJNR/L-12-4B	53018	53019	0.75	0.75	4.50	1.500	1.000	432	JD-432	SM-S4	JSLC-HPD4	JSCS-04	JSOR-01	JSOR-04
ADDJNR/L-16-4D	53020	53021	1.00	1.00	6.00	1.500	1.250	432	JD-432	SM-S4	JSLC-HPD4	JSCS-04	JSOR-01	JSOR-04
ADDJNR/L-20-4D	53022	53023	1.25	1.25	6.00	1.500	1.500	432	JD-432	SM-S4	JSLC-HPD4	JSCS-04	JSOR-01	JSOR-04
*ADDJNR/L-24-4E	53024	53025	1.50	1.50	7.00	1.500	2.000	432	JD-432	SM-S4	JSLC-HPD4	JSCS-04	JSOR-01	JSOR-04

\*Special Order, available upon request. One standard coolant connector kit with tubing is supplied, see page B-49 for details and high pressure coolant fitting. For Turning inserts see Sect.A. For spare parts see page B-50.

**ADDPNN Toolholder Style P - 27.5° side cutting lead angle for negative 55° diamond DNM\_inserts**

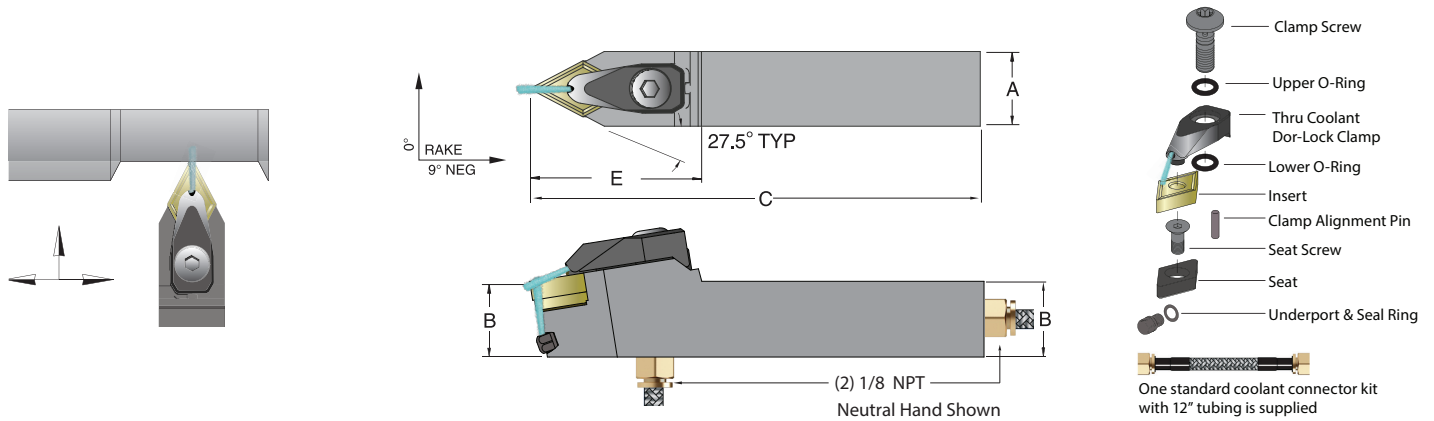

Inch Description	UPC No. 733101-Neutral	A	B	C	E	DNM Gage Insert	Seat	Seat Screw	Dor-Lock Clamp	Clamp Screw	Upper 'O' Ring	Lower 'O' Ring
ADDPNN-12-3B	53030	0.75	0.75	4.50	1.750	332	IDSN-322	SM-M4-245	JSLC-HPD3	JSCS-04	JSOR-01	JSOR-04
ADDPNN-12-4B	53031	0.75	0.75	4.50	1.750	432	JD-432	SM-S4	JSLC-HPD4	JSCS-04	JSOR-01	JSOR-04
ADDPNN-16-3D	53032	1.00	1.00	6.00	1.750	332	IDSN-322	SM-M4-245	JSLC-HPD3	JSCS-04	JSOR-01	JSOR-04
ADDPNN-16-4D	53033	1.00	1.00	6.00	1.750	432	JD-432	SM-S4	JSLC-HPD4	JSCS-04	JSOR-01	JSOR-04
ADDPNN-20-4D	53034	1.25	1.25	6.00	1.750	432	JD-432	SM-S4	JSLC-HPD4	JSCS-04	JSOR-01	JSOR-04
*ADDPNN-24-4E	53035	1.50	1.50	7.00	1.750	432	JD-432	SM-S4	JSLC-HPD4	JSCS-04	JSOR-01	JSOR-04

\*Special Order, available upon request. One standard coolant connector kit with tubing is supplied, see page B-49 for details and high pressure coolant fitting. For Turning inserts see Sect.A. For spare parts see page B-50.

**ADSDNN Toolholder Style D - 45° side cutting lead angle for negative square SNM\_inserts**

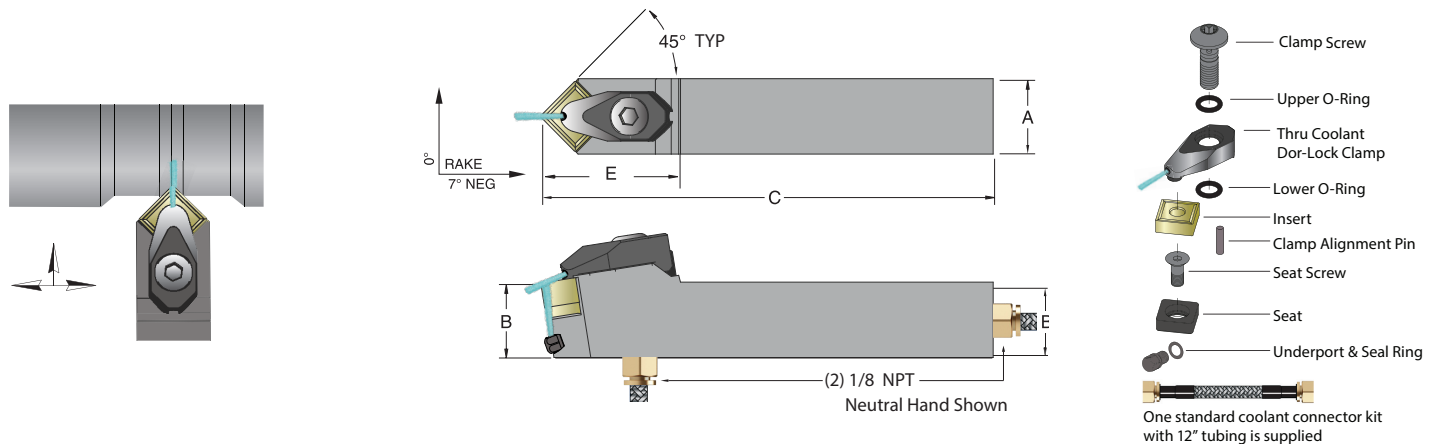

Inch Description	UPC No. 733101-Neutral	A	B	C	E	SNM Gage Insert	Seat	Seat Screw	Dor-Lock Clamp	Clamp Screw	Upper 'O' Ring	Lower 'O' Ring
ADSDNN-12-4B	53053	0.75	0.75	4.50	1.375	432	JS-432	SM-S4	JSLC-HPCTW-4N	JSCS-04	JSOR-01	JSOR-04
ADSDNN-16-4D	53054	1.00	1.00	6.00	1.375	432	JS-432	SM-S4	JSLC-HPCTW-4N	JSCS-04	JSOR-01	JSOR-04
ADSDNN-20-4D	53055	1.25	1.25	6.00	1.375	432	JS-432	SM-S4	JSLC-HPCTW-4N	JSCS-04	JSOR-01	JSOR-04
ADSDNN-20-5D	53056	1.25	1.25	6.00	1.375	543	JS-533	SM-M6	JSLC-HPC5	JSCS-04	JSOR-01	JSOR-04
*ADSDNN-24-5E	53058	1.50	1.50	7.00	1.625	543	JS-533	SM-M6	JSLC-HPC5	JSCS-04	JSOR-01	JSOR-04

\*Special Order, available upon request. One standard coolant connector kit with tubing is supplied, see page B-49 for details and high pressure coolant fitting. For Turning inserts see Sect.A. For spare parts see page B-50.

**ADSRN R/L Toolholder Style R - 15° side cutting lead angle for negative square SNM\_inserts**

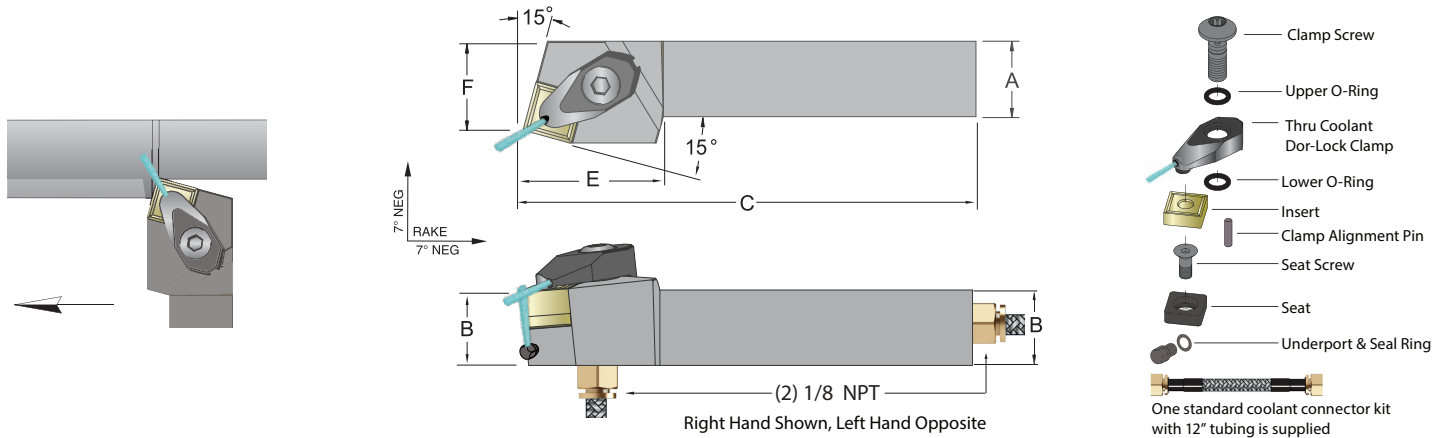

Inch Description	UPC No. 733101-		A	B	C	E	F	SNM_ Gage Insert	Seat	Seat Screw	Dor-Lock Clamp	Clamp Screw	Upper 'O' Ring	Lower 'O' Ring
	R.H.	L.H.												
ADSRNR/L-12-4B	53040	53041	0.75	0.75	4.50	1.375	0.880	432	JS-432	SM-S4	JSLC-HPCTW-4N	JSCS-04	JSOR-01	JSOR-04
ADSRNR/L-16-4D	53043	53044	1.00	1.00	6.00	1.375	1.000	432	JS-432	SM-S4	JSLC-HPCTW-4N	JSCS-04	JSOR-01	JSOR-04
ADSRNR/L-20-5D	53045	53046	1.25	1.25	6.00	1.375	1.000	543	JS-533	SM-M6	JSLC-HPC5	JSCS-04	JSOR-01	JSOR-04
*ADSRNR/L-24-5E	53047	53048	1.50	1.50	7.00	1.375	1.000	543	JS-533	SM-M6	JSLC-HPC5	JSCS-04	JSOR-01	JSOR-04

\*Special Order, available upon request. One standard coolant connector kit with tubing is supplied, see page B-49 for details and high pressure coolant fitting. For Turning inserts see Sect.A. For spare parts see page B-50.

**ADTENN Toolholder Style E - 30° side cutting lead angle for negative triangle TNM\_inserts**

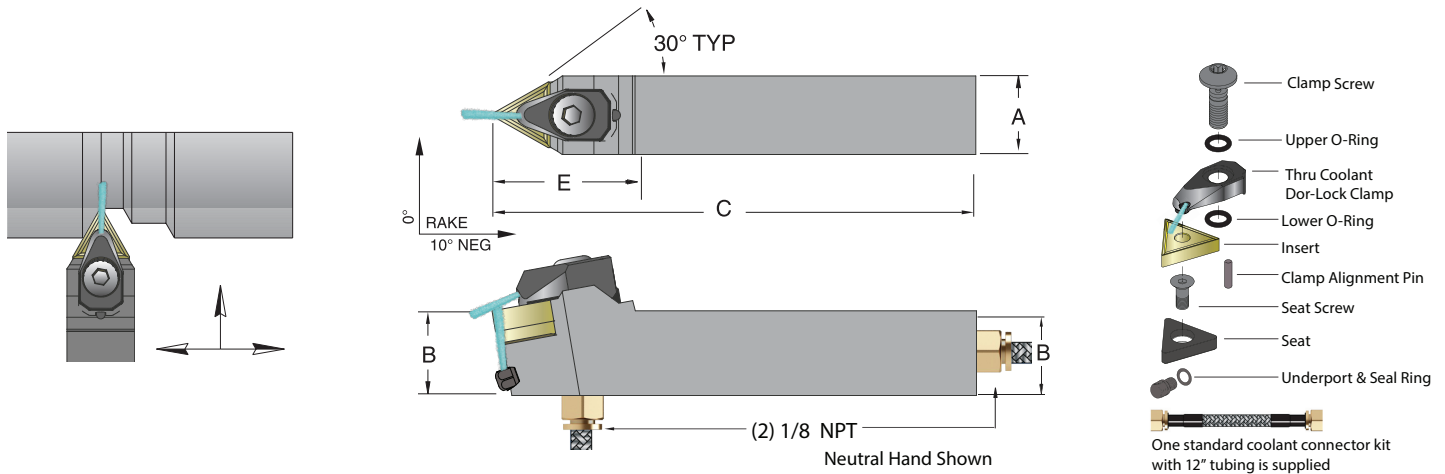

Inch Description	UPC No. 733101-	A	B	C	E	TNM_ Gage Insert	Seat	Seat Screw	Dor-Lock Clamp	Clamp Screw	Upper 'O' Ring	Lower 'O' Ring
	Neutral											
ADTENN-12-3B	53075	0.75	0.75	4.50	1.375	332	JT-322	SM-M3-T	JSLC-HPTW3N	JSCS-04	JSOR-01	JSOR-04
ADTENN-12-4B	53076	0.75	0.75	4.50	1.375	432	JT-433	SM-S4	JSLC-HPCTW-4N	JSCS-04	JSOR-01	JSOR-04
ADTENN-16-3D	53077	1.00	1.00	6.00	1.375	332	JT-322	SM-M3-T	JSLC-HPTW3N	JSCS-04	JSOR-01	JSOR-04
ADTENN-16-4D	53078	1.00	1.00	6.00	1.375	432	JT-433	SM-S4	JSLC-HPCTW-4N	JSCS-04	JSOR-01	JSOR-04
ADTENN-20-4D	53079	1.25	1.25	6.00	1.500	432	JT-433	SM-S4	JSLC-HPCTW-4N	JSCS-04	JSOR-01	JSOR-04
*ADTENN-24-4E	53080	1.50	1.50	7.00	1.625	432	JT-433	SM-S4	JSLC-HPCTW-4N	JSCS-04	JSOR-01	JSOR-04

\*Special Order, available upon request. One standard coolant connector kit with tubing is supplied, see page B-49 for details and high pressure coolant fitting. For Turning inserts see Sect.A. For spare parts see page B-50.



**ADTJN R/L Toolholder Style J - 3° side cutting lead angle for negative triangle TNM\_ inserts**

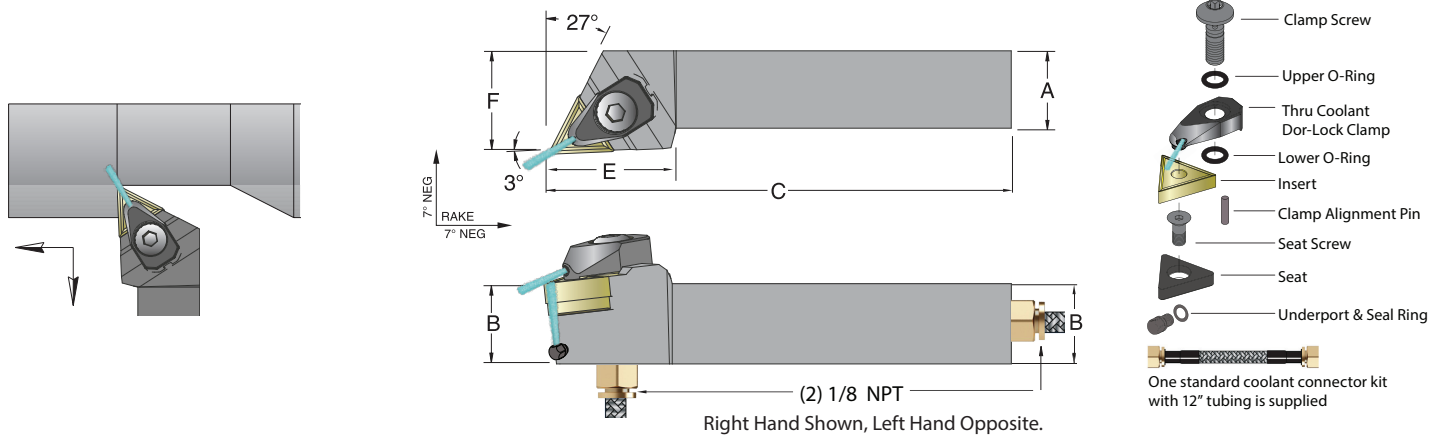

Inch Description	UPC No. 733101-		A	B	C	E	F	TNM_ Gage Insert	Seat	Seat Screw	Dor-Lock Clamp	Clamp Screw	Upper 'O' Ring	Lower 'O' Ring
	R.H.	L.H.												
ADTJNR/L-12-3B	53063	53064	0.75	0.75	4.50	1.250	1.000	332	JT-322	SM-M3-T	JSLC-HPTW3N	JSCS-04	JSOR-01	JSOR-04
ADTJNR/L-12-4B	53065	53066	0.75	0.75	4.50	1.250	1.250	432	JT-433	SM-S4	JSLC-HPCTW-4N	JSCS-04	JSOR-01	JSOR-04
ADTJNR/L-16-3D	53067	53068	1.00	1.00	6.00	1.250	1.500	332	JT-322	SM-M3-T	JSLC-HPTW3N	JSCS-04	JSOR-01	JSOR-04
ADTJNR/L-16-4D	53069	53070	1.00	1.00	6.00	1.250	2.000	432	JT-433	SM-S4	JSLC-HPCTW-4N	JSCS-04	JSOR-01	JSOR-04
ADTJNR/L-20-4D	53071	53072	1.25	1.25	6.00	1.375	2.000	432	JT-433	SM-S4	JSLC-HPCTW-4N	JSCS-04	JSOR-01	JSOR-04
*ADTJNR/L-24-4E	53073	53074	1.50	1.50	7.00	1.500	2.000	432	JT-433	SM-S4	JSLC-HPCTW-4N	JSCS-04	JSOR-01	JSOR-04

\*Special Order, available upon request. One standard coolant connector kit with tubing is supplied, see page B-49 for details and high pressure coolant fitting. For Turning inserts see Sect. A. For spare parts see page B-50.

**ADVJN R/L Toolholder Style J - Negative 3° side cutting lead angle for negative 35° diamond VNM\_ inserts**

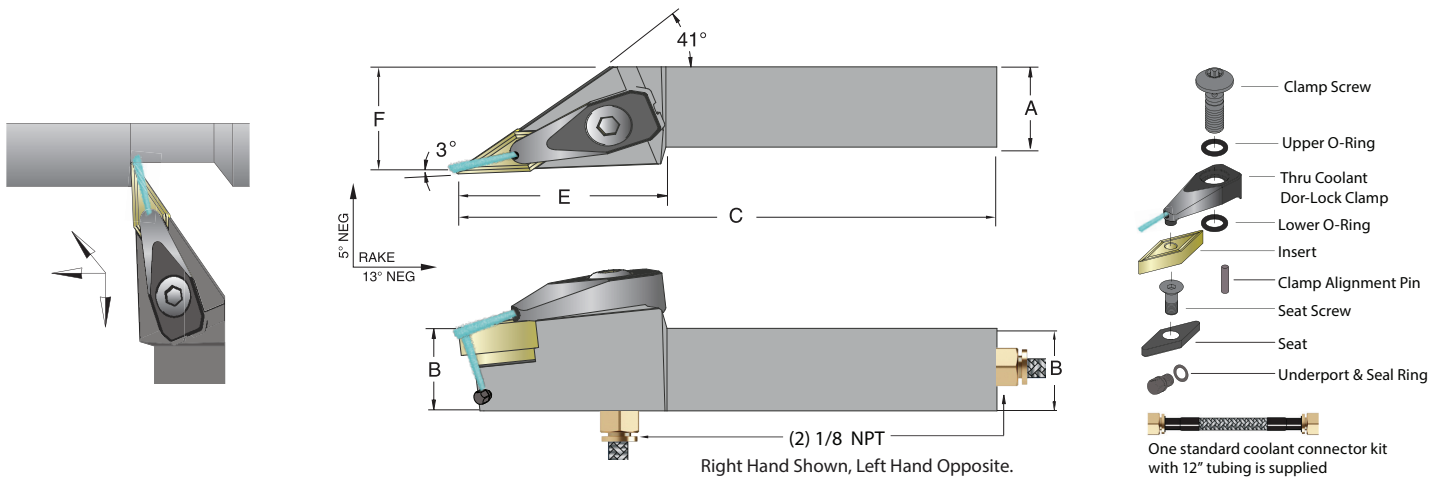

Inch Description	UPC No. 733101-		A	B	C	E	F	VNM_ Gage Insert	Seat	Seat Screw	Dor-Lock Clamp	Clamp Screw	Upper 'O' Ring	Lower 'O' Ring
	R.H.	L.H.												
ADVJNR/L-12-3B	53081	53082	0.75	0.75	4.50	1.750	1.000	332	JV-322	SM-M3	JSLC-HPV3	JSCS-04	JSOR-01	JSOR-04
ADVJNR/L-16-3D	53083	53084	1.00	1.00	6.00	1.750	1.250	332	JV-322	SM-M3	JSLC-HPV3	JSCS-04	JSOR-01	JSOR-04
ADVJNR/L-20-3D	53085	53086	1.25	1.25	6.00	1.750	1.500	332	JV-322	SM-M3	JSLC-HPV3	JSCS-04	JSOR-01	JSOR-04
*ADVJNR/L-24-3E	53087	53088	1.50	1.50	7.00	1.750	2.000	332	JV-322	SM-M3	JSLC-HPV3	JSCS-04	JSOR-01	JSOR-04

\*Special Order, available upon request. One standard coolant connector kit with tubing is supplied, see page B-49 for details and high pressure coolant fitting. For Turning inserts see Sect.A. For spare parts see page B-50.

**ADWLN R/L Toolholder Style L - Negative 5° end or side cutting lead angle for negative 80° trigon WNM\_ inserts**

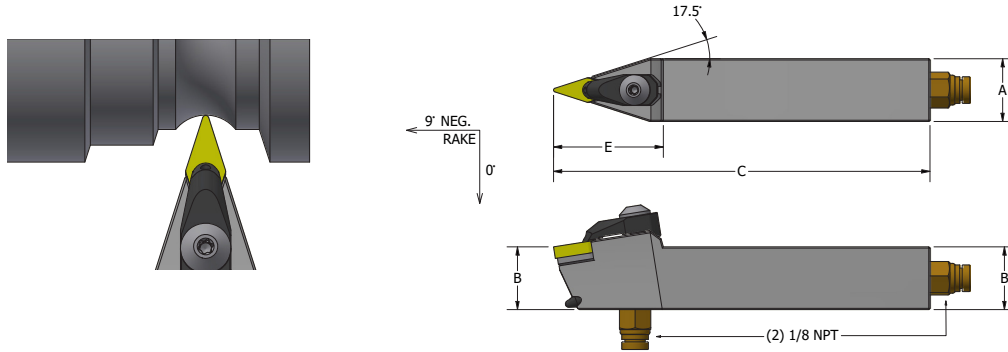

Inch Description	UPC No. 733101-Neutral	A	B	C	E	VNM Gage Insert	Seat	Seat Screw	Dor-Lock Clamp	Clamp Screw	Upper "O" Ring	Lower "O" Ring	Lower "O" Ring
ADVNN-16-3D	53060	1.00	1.00	6.00	1.75	332	JV-322	SM-M3	JSLC-HPV3	JSCS-04	JSOR-01	JSOR-04	JSOR-04
ADVNN-20-3D	53061	1.00	1.00	6.00	1.75	332	JV-322	SM-M3	JSLC-HPV3	JSCS-04	JSOR-01	JSOR-04	JSOR-04
*ADWLN/L-24-4E	53103	1.50	1.50	7.00	1.250	2.000	432	IWSN-433	SM-S4	*JSLC-HPTW4R/L	JSCS-04	JSOR-01	JSOR-04

\*Special Order, available upon request. One standard coolant connector kit with tubing is supplied, see page B-49 for details and high pressure coolant fitting. For Turning inserts see Sect. A. For spare parts see page B-50.

**ADWLN R/L Toolholder Style L - Negative 5° end or side cutting lead angle for negative 80° trigon WNM\_ inserts**

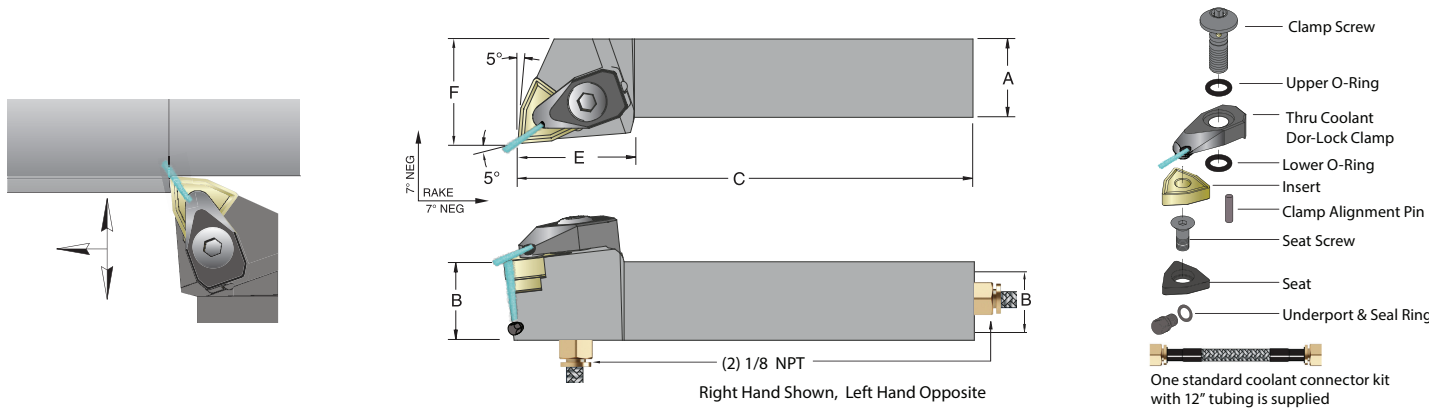



Inch Description	UPC No. 733101-R.H.	UPC No. 733101-L.H.	A	B	C	E	F	WNM Gage Insert	Seat	Seat Screw	Dor-Lock Clamp	Clamp Screw	Upper "O" Ring	Lower "O" Ring
ADWLN/L-12-3B	53093	53094	0.75	0.75	4.50	1.000	1.000	332	IWSN-322	SM-M4-245	*JSLC-HPTW3R/L	JSCS-04	JSOR-01	JSOR-04
ADWLN/L-12-4B	53095	53096	0.75	0.75	4.50	1.250	1.000	432	IWSN-433	SM-S4	*JSLC-HPTW4R/L	JSCS-04	JSOR-01	JSOR-04
ADWLN/L-16-3D	53097	53098	1.00	1.00	6.00	1.000	1.250	332	IWSN-322	SM-M4-245	*JSLC-HPTW3R/L	JSCS-04	JSOR-01	JSOR-04
ADWLN/L-16-4D	53099	53100	1.00	1.00	6.00	1.375	1.250	432	IWSN-433	SM-S4	*JSLC-HPTW4R/L	JSCS-04	JSOR-01	JSOR-04
ADWLN/L-20-4D	53101	53102	1.25	1.25	6.00	1.250	1.500	432	IWSN-433	SM-S4	*JSLC-HPTW4R/L	JSCS-04	JSOR-01	JSOR-04
*ADWLN/L-24-4E	53103	53104	1.50	1.50	7.00	1.250	2.000	432	IWSN-433	SM-S4	*JSLC-HPTW4R/L	JSCS-04	JSOR-01	JSOR-04

\*Special Order, available upon request. One standard coolant connector kit with tubing is supplied, see page B-49 for details and high pressure coolant fitting. For Turning inserts see Sect. A. For spare parts see page B-50.

A.N.S.I. (American National Standards Institute)  
AS-16R-ADCLNR/L-4

I.S.O. (International Standards Organization)  
AS-20R-ADCLNR/L-09

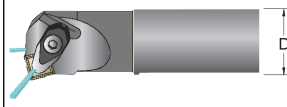
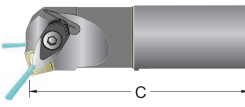
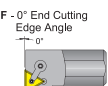
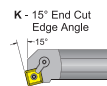
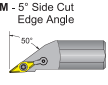
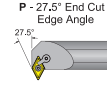
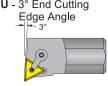
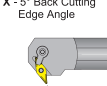

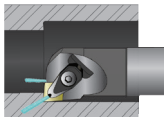
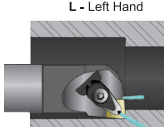







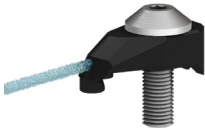



# Boring Identification System

<p><b>AS</b> - Steel With Coolant  <b>C</b> - Carbide  <b>E</b> - Carbide With Coolant  <b>S</b> - Steel</p>	<p><b>Round Shanks:</b> (D) shown in 1/16 inch increments</p>  <p><b>Round Shanks:</b> (D) shown in 1 mm increments</p> 	<p><b>H</b> - 4.0    <b>S</b> - 10.0  <b>J</b> - 4.5    <b>T</b> - 12.0  <b>K</b> - 5.0    <b>U</b> - 14.0  <b>M</b> - 6.0    <b>V</b> - 16.0  <b>R</b> - 8.0    <b>Y</b> - 18.0</p> <p><b>H</b> - 100 mm    <b>R</b> - 200 mm  <b>J</b> - 110 mm    <b>S</b> - 250 mm  <b>K</b> - 125 mm    <b>T</b> - 300 mm  <b>M</b> - 150 mm    <b>U</b> - 350 mm  <b>Q</b> - 180 mm</p>	       	<p><b>R</b> - Right Hand</p>  <p><b>L</b> - Left Hand</p> 
--	--	---	--	--

1. Bar Type	2. Bar Diameter (in) (mm)	3. Bar Length	6. Bar Style	8. Hand of Tool
-------------	---------------------------	---------------	--------------	-----------------

1.	2.	3.	4.	5.	6.	7.	8.	9.
<b>AS</b>	<b>16</b> <b>20</b>	<b>R</b>	<b>AD</b>	<b>C</b>	<b>L</b>	<b>N</b>	<b>R/L</b>	<b>4</b> <b>12</b>

4. Clamp Style	5. Insert Shape	7. Insert Clearance Angle	9. Insert Size (in) Insert Length (mm)
----------------	-----------------	---------------------------	--

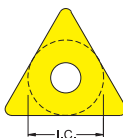
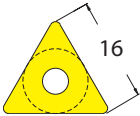
	<p><b>C</b> - 80° Diamond    <b>T</b> - Triangle</p>   <p><b>D</b> - 55° Diamond    <b>W</b> - 80° Trigon</p>   <p><b>R</b> - Round    <b>V</b> - 35° Diamond</p>   <p><b>S</b> - Square    <b>K</b> - 55° Diamond</p>  	<p><b>B</b> - 5° Positive</p>  <p><b>C</b> - 7° Positive</p>  <p><b>E</b> - 20° Positive</p>  <p><b>N</b> - 0° Negative</p>  <p><b>P</b> - 11° Positive</p> 	<p>Insert Size (in)    Insert Length (mm)</p> <p>Insert I.C. shown in 1/8" increments    Length shown in 1mm increments</p>  
---	--	--	---

**AS-ADCLN R/L Boring Bar Style L - Negative 5° side & end cutting lead angle for negative 80° diamond CNM\_inserts**

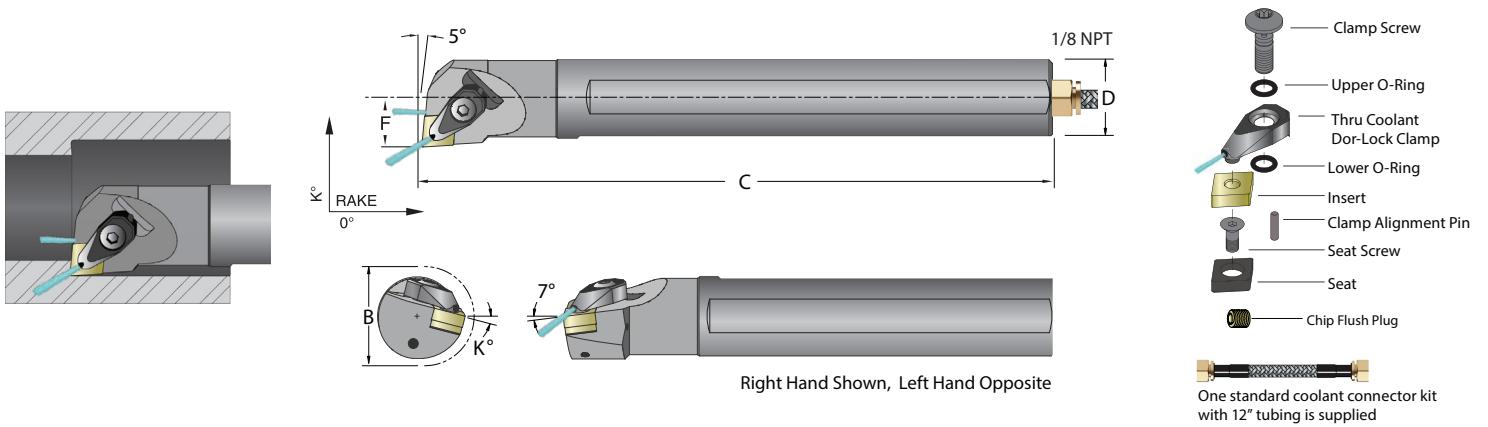

Inch Description	UPC No. 733101-		Min. Bore					K°	CNM_		Seat Screw	Dor-Lock Clamp	Clamp Screw	Upper 'O' Ring	Lower 'O' Ring	Chip Flush Plug
	R.H.	L.H.	B	C	D	F	Gage Insert		Seat							
AS-12R-ADCLNR/L-3	53120	53121	1.000	8.00	0.75	0.500	10°	322	N/A	N/A	JSLC-HPC3-B	JSCS-03	JSOR-03	JSOR-06	JSPN-M3	
AS-16R-ADCLNR/L-4	53122	53123	1.475	8.00	1.00	0.640	14°	432	ICSN-423	SM-S4	JSLC-HPCTW-4N	JSCS-04	JSOR-01	JSOR-04	JSPN-M6	
AS-20S-ADCLNR/L-4	53124	53125	1.530	10.00	1.25	0.765	14°	432	JC-432	SM-S4	JSLC-HPCTW-4N	JSCS-04	JSOR-01	JSOR-04	JSPN-M6	
AS-24S-ADCLNR/L-4	53126	53127	1.780	10.00	1.50	0.890	11°	432	JC-432	SM-S4	JSLC-HPCTW-4N	JSCS-04	JSOR-01	JSOR-04	JSPN-M6	
AS-32T-ADCLNR/L-4	53128	-	2.562	12.00	2.00	1.281	11°	432	JC-432	SM-S4	JSLC-HPCTW-4N	JSCS-04	JSOR-01	JSOR-04	JSPN-M6	
AS-32T-ADCLNR/L-5	53130	53131	2.562	12.00	2.00	1.281	11°	543	JC-533	SM-M6	JSLC-HPC5	JSCS-04	JSOR-01	JSOR-04	JSPN-M6	

One standard coolant connector kit with tubing is supplied, see page B-49 for details and high pressure coolant fitting. For Turning inserts see Sect.A. For spare parts see page B-50.

**AS-ADTUN R/L Boring Bar Style U - Negative 3° end cutting lead angle for negative triangle TNM\_inserts**

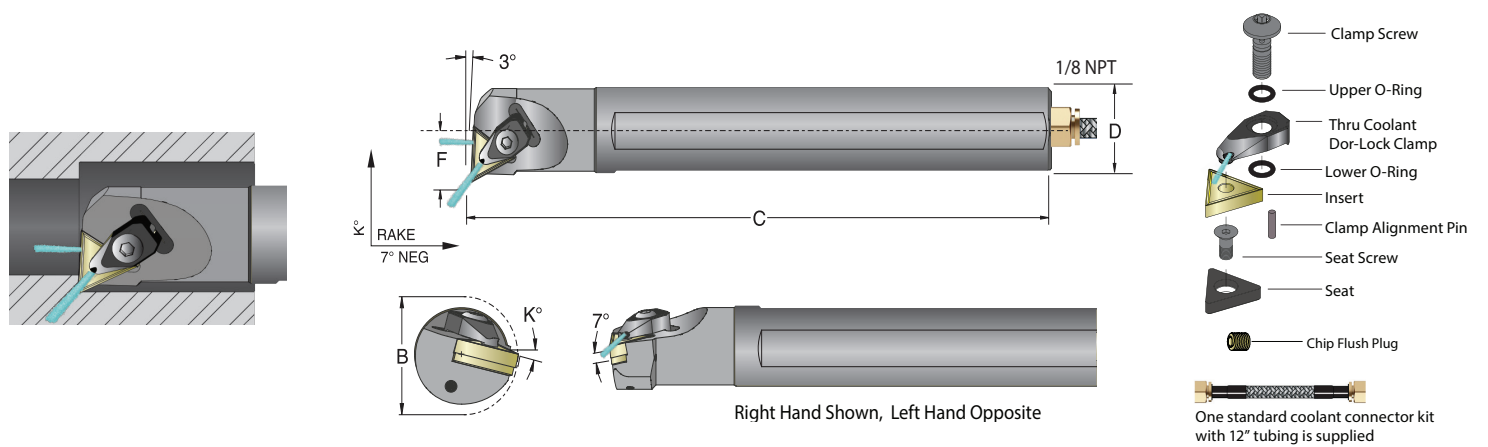

Inch Description	UPC No. 733101-		Min. Bore					K°	TNM_		Seat Screw	Dor-Lock Clamp	Clamp Screw	Upper 'O' Ring	Lower 'O' Ring	Chip Flush Plug
	R.H.	L.H.	B	C	D	F	Gage Insert		Seat							
AS-12R-ADTUNR/L-3	53172	53173	1.000	8.00	0.75	0.500	14°	322	N/A	N/A	*JSLC-HPDT3-BR/L	JSCS-03	JSOR-03	JSOR-06	JSPN-M3	
AS-16R-ADTUNR/L-3	53174	53175	1.280	8.00	1.00	0.640	14°	332	JT-322	SM-M3-T	*JSLC-HPDT3-BR/L	JSCS-03	JSOR-03	JSOR-06	JSPN-M3	
AS-20S-ADTUNR/L-4	53176	53177	1.530	10.00	1.25	0.765	14°	432	JT-433	SM-S4	*JSLC-HPTW4R/L	JSCS-04	JSOR-01	JSOR-04	JSPN-M6	
AS-24S-ADTUNR/L-4	53178	53179	2.060	10.00	1.50	0.890	11°	432	JT-433	SM-S4	*JSLC-HPTW4R/L	JSCS-04	JSOR-01	JSOR-04	JSPN-M6	
AS-32T-ADTUNR/L-4	53180	53181	2.562	12.00	2.00	1.281	11°	432	JT-433	SM-S4	*JSLC-HPTW4R/L	JSCS-04	JSOR-01	JSOR-04	JSPN-M6	

One standard coolant connector kit with tubing is supplied, see page B-49 for details and high pressure coolant fitting. For Turning inserts see Sect. A. For spare parts see page B-50. \*Right clamp for right hand toolholder. Left clamp for left hand toolholder

**AS-ADDUN R/L Boring Bar Style U - Negative 3° end cutting lead angle for negative 55° diamond DNM\_inserts**

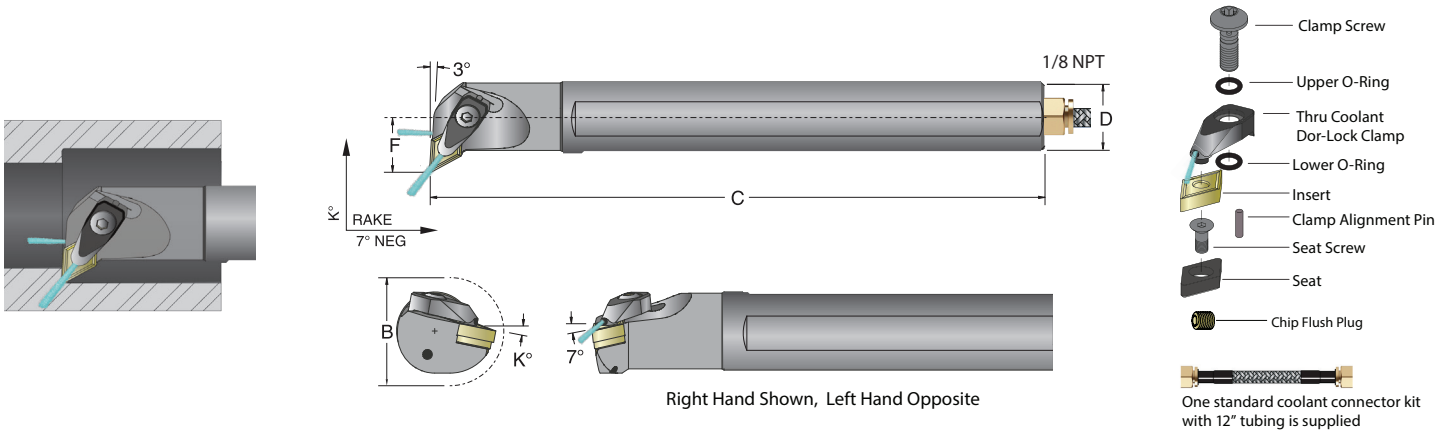

Inch Description	UPC No. 733101-		Min. Bore					K°	DNM_Gage Insert	Seat	Seat Screw	Dor-Lock Clamp	Clamp Screw	Upper 'O' Ring	Lower 'O' Ring	Chip Flush Plug
	R.H.	L.H.	B	C	D	F										
AS-16R-ADDUNR/L-3	53137	53138	1.300	8.00	1.00	0.750	14°	332	IDSN-322	SM-M3	*JSLC-HPDT3-BR/L	JSCS-03	JSOR-03	JSOR-06	JSPN-M3	
AS-20S-ADDUNR/L-4	53139	53140	2.000	10.00	1.25	1.000	11°	432	JD-432	SM-S4	JSLC-HPD4	JSCS-04	JSOR-01	JSOR-04	JSPN-M6	
AS-24S-ADDUNR/L-4	53141	53142	2.250	10.00	1.50	1.125	11°	432	JD-432	SM-S4	JSLC-HPD4	JSCS-04	JSOR-01	JSOR-04	JSPN-M6	
AS-32T-ADDUNR/L-4	53143	53144	3.000	12.00	2.00	1.375	11°	432	JD-432	SM-S4	JSLC-HPD4	JSCS-04	JSOR-01	JSOR-04	JSPN-M6	

One standard coolant connector kit with tubing is supplied, see page B-49 for details and high pressure coolant fitting. For Turning inserts see Sect: A. For spare parts see page B-50.  
 \*Right clamp for right hand toolholder. Left clamp for left hand toolholder

**AS-ADDPN R/L Boring Bar Style P- Negative 27.5 end cutting lead angle for negative 55° diamond DNM\_inserts**

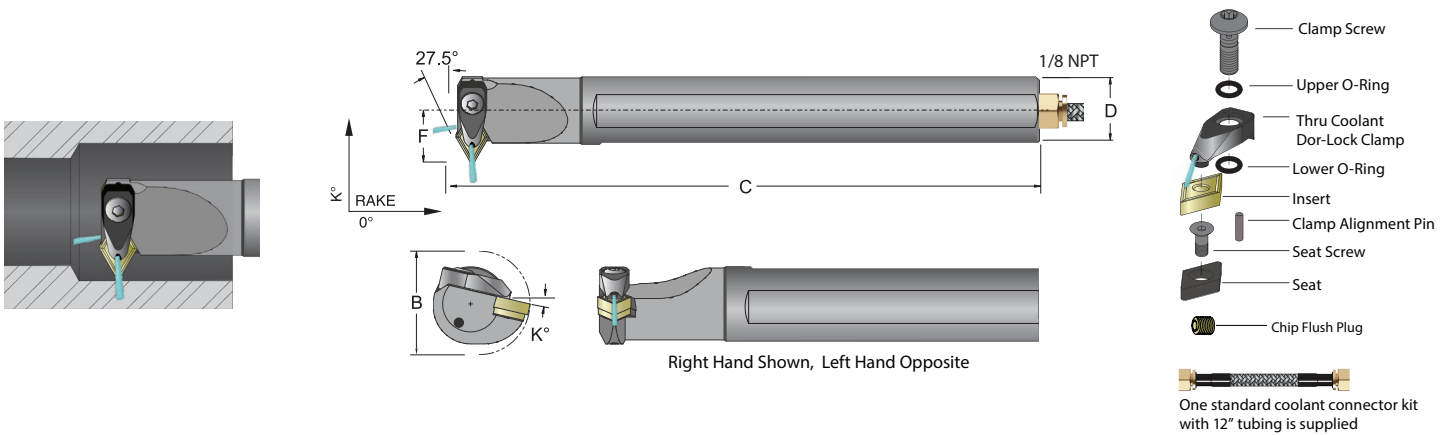

Inch Description	UPC No. 733101-		Min. Bore					K°	DNM_Gage Insert	Seat	Seat Screw	Dor-Lock Clamp	Clamp Screw	Upper 'O' Ring	Lower 'O' Ring	Chip Flush Plug
	R.H.	L.H.	B	C	D	F										
AS-20S-ADDPNR/L-4	53150	53151	1.705	10.00	1.25	1.000	13°	432	JD-432	SM-S4	JSLC-HPD4	JSCS-04	JSOR-01	JSOR-04	JSPN-M6	
AS-24S-ADDPNR/L-4	53152	53153	2.000	10.00	1.50	1.125	10°	432	JD-432	SM-S4	JSLC-HPD4	JSCS-04	JSOR-01	JSOR-04	JSPN-M6	

One standard coolant connector kit with tubing is supplied, see page B-49 for details and high pressure coolant fitting. For Turning inserts see Sect: A. For spare parts see page B-50.



**AS-ADSKN R/L Boring Bar Style K - 15° End cutting lead angle for negative square SNM\_ inserts**

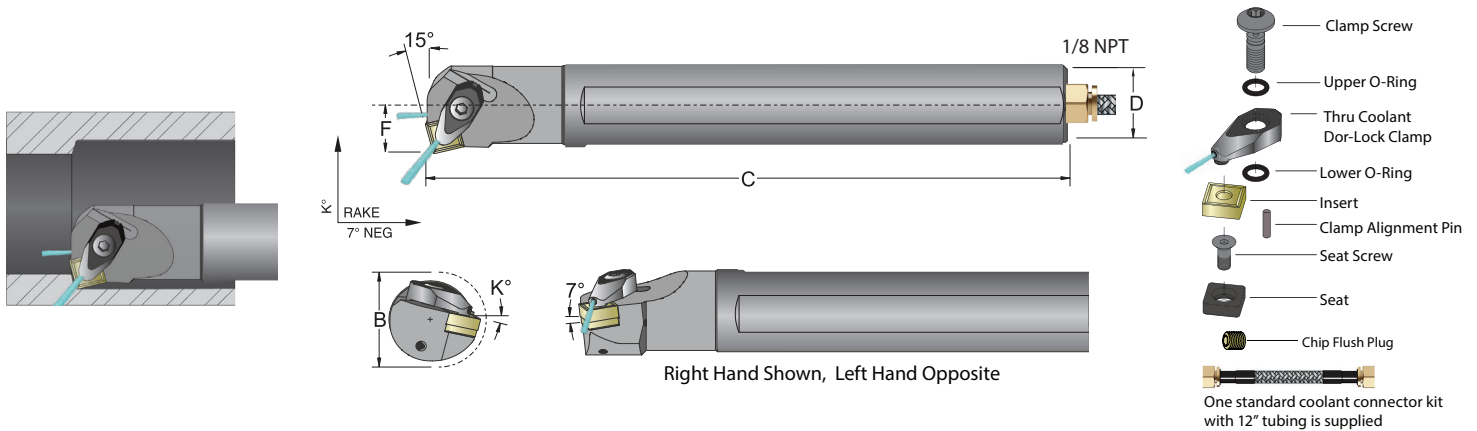

Inch Description	UPC No. 733101-		Min. Bore					K°	SNM_ Gage Insert	Seat	Seat Screw	Dor-Lock Clamp	Clamp Screw	Upper 'O' Ring	Lower 'O' Ring	Chip Flush Plug
	R.H.	L.H.	B	C	D	F										
AS-20S-ADSKNR/L-4	53159	53160	1.53	10.00	1.25	0.765	10°	432	JS-432	SM-S4	JSLC-HPCTW-4N	JSCS-04	JSOR-01	JSOR-04	JSPN-M6	
AS-24S-ADSKNR/L-4	53161	53162	1.76	10.00	1.50	0.890	11°	432	JS-432	SM-S4	JSLC-HPCTW-4N	JSCS-04	JSOR-01	JSOR-04	JSPN-M6	
AS-32T-ADSKNR/L-4	53163	-	2.400	12.00	2.00	1.281	12°	432	JS-432	SM-S4	JSLC-HPCTW-4N	JSCS-04	JSOR-01	JSOR-04	JSPN-M6	
AS-32T-ADSKNR/L-5	53165	53166	2.400	12.00	2.00	1.281	12°	543	JS-533	SM-M6	JSLC-HPC5	JSCS-04	JSOR-01	JSOR-04	JSPN-M6	

One standard coolant connector kit with tubing is supplied, see page B-49 for details and high pressure coolant fitting. For Turning inserts see pages A-58 - A-88. For spare parts see page B-50.

**AS-ADVUN R/L Boring Bar Style U - Negative 3° side cutting lead angle for negative 35° diamond VNM\_ inserts**

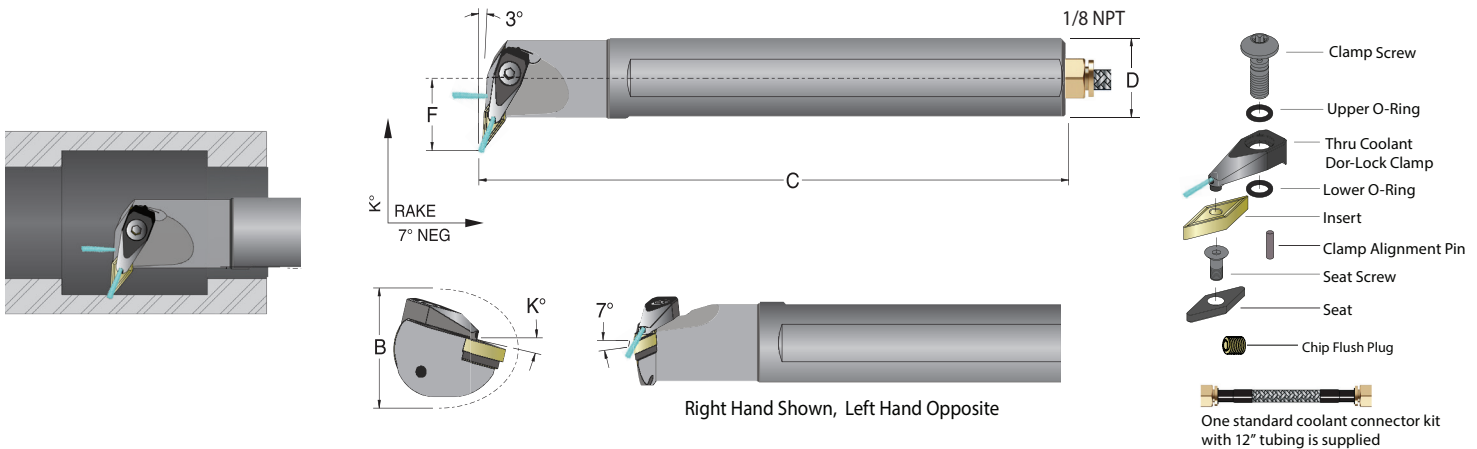

Inch Description	UPC No. 733101-		Min. Bore					K°	VNM_ Gage Insert	Seat	Seat Screw	Dor-Lock Clamp	Clamp Screw	Upper 'O' Ring	Lower 'O' Ring	Chip Flush Plug
	R.H.	L.H.	B	C	D	F										
AS-20S-ADVUNR/L-3	53189	53190	2.250	10.00	1.25	1.125	14°	332	JV-322	SM-M3	JSLC-HPV3	JSCS-04	JSOR-01	JSOR-04	JSPN-M6	
AS-24S-ADVUNR/L-3	53191	53192	2.500	10.00	1.50	1.250	11°	332	JV-322	SM-M3	JSLC-HPV3	JSCS-04	JSOR-01	JSOR-04	JSPN-M6	

One standard coolant connector kit with tubing is supplied, see page B-49 for details and high pressure coolant fitting. For Turning inserts see Sect: A. For spare parts see page B-50.

**AS-ADWLN R/L Boring Bar Style L - Negative 5° end & side cutting lead angle for negative 80° trigon WNM\_inserts**

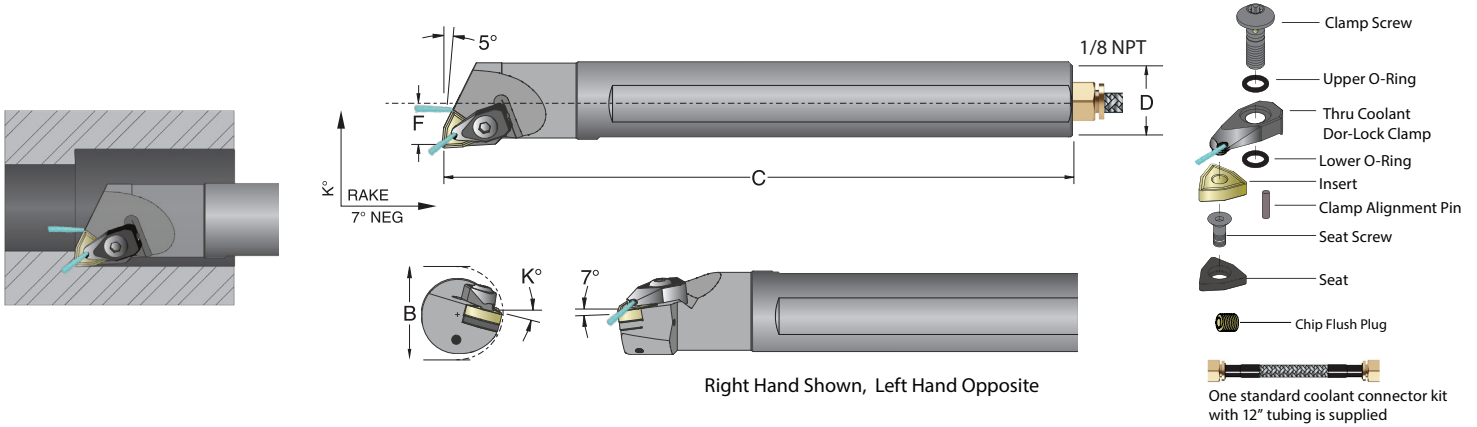

Inch Description	UPC No. 733101-		Min. Bore					K°	WNM_ Gage Insert	Seat	Seat Screw	Dor-Lock Clamp	Clamp Screw	Upper 'O' Ring	Lower 'O' Ring	Chip Flush Plug
	R.H.	L.H.	B	C	D	F										
AS-12R-ADWLN/R-3	53198	53199	1.000	8.00	0.75	0.500	14°	332	N/A	N/A	*JSLC-HPW3-R/L	JSCS-03	JSOR-03	JSOR-06	JSPN-M3	
AS-16R-ADWLN/R-4	53200	53201	1.280	8.00	1.00	0.640	14°	432	IWSN-433	SM-S4	*JSLC-HPTW-4R/L	JSCS-04	JSOR-01	JSOR-04	JSPN-M6	
AS-20S-ADWLN/R-4	53202	53203	1.530	10.00	1.25	0.765	14°	432	IWSN-433	SM-S4	*JSLC-HPTW-4R/L	JSCS-04	JSOR-01	JSOR-04	JSPN-M6	
AS-24S-ADWLN/R-4	53204	53205	1.780	10.00	1.50	0.890	11°	432	IWSN-433	SM-S4	*JSLC-HPTW-4R/L	JSCS-04	JSOR-01	JSOR-04	JSPN-M6	
AS-32T-ADWLN/R-4	53206	53207	2.000	12.00	2.00	1.281	12°	432	IWSN-433	SM-S4	*JSLC-HPTW-4R/L	JSCS-04	JSOR-01	JSOR-04	JSPN-M6	

One standard coolant connector kit with tubing is supplied, see page B-49 for details and high pressure coolant fitting. For Turning inserts see Sect: A. For spare parts see page B-50. \*Right clamp for right hand toolholder. Left clamp for left hand toolholder

Enhance Performance in:

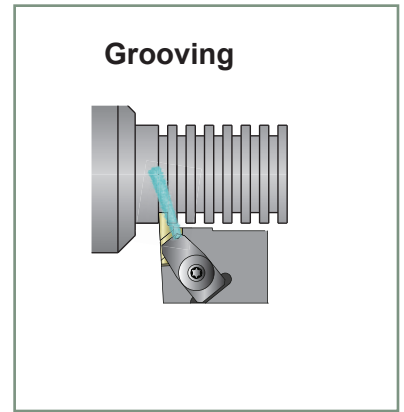
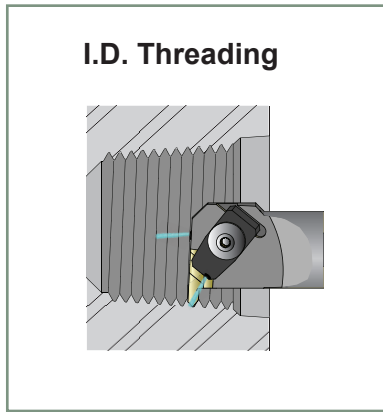
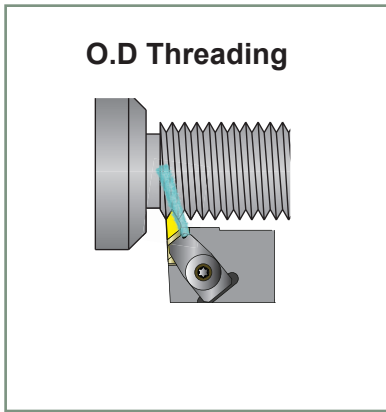

Threading and Grooving - Selection Chart

On Edge Style	Machining Applications		Insert Shape			
	Best	Good	Threading		Grooving	
	Threading	Grooving	Positive	Negative	Positive	Negative
External						
Internal						

Laydown Style	Machining Applications		Insert Shape			
	Best	Not Available	Threading		Grooving	
	Threading	Grooving				
External						
Internal					Not Available	

DorNotch Style	Machining Applications		Insert Shape			
	Good	Best	Threading		Grooving	
	Threading	Grooving	Positive	Neutral	Positive	Neutral
External						
Internal						

For Threading technical data, inserts and standard non coolant tools see catalog section D-1- D-70.



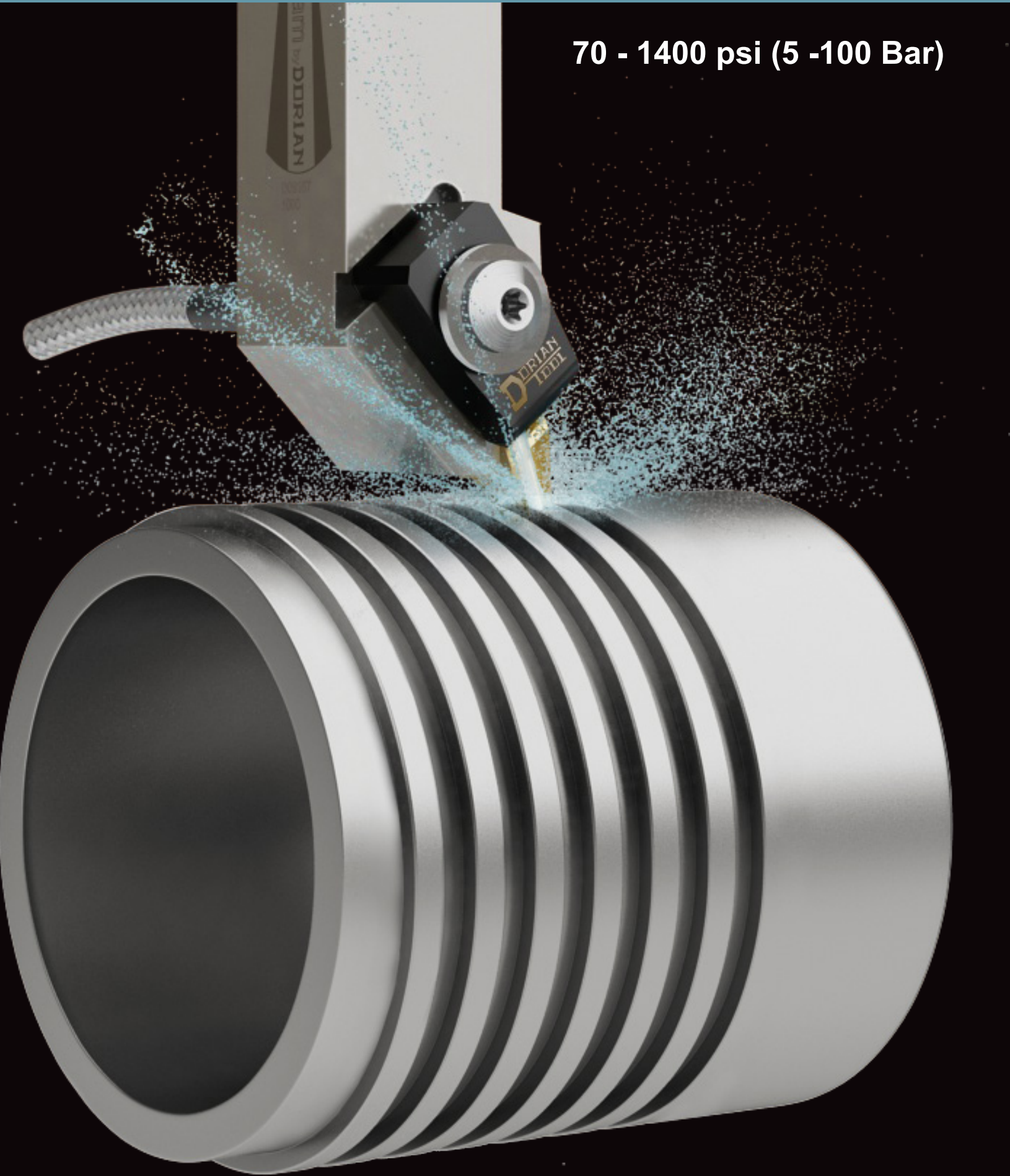

70 - 1400 psi (5 -100 Bar)



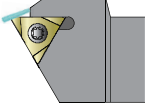

A.N.S.I. (American National Standards Institute)  
ADTVOR/L16-4D



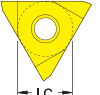

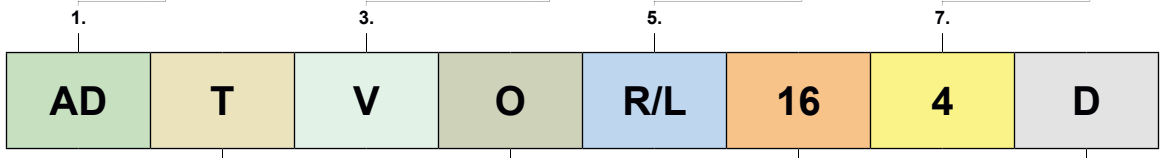

# OnEdge Identification System

 <p>AD- Thru Coolant</p>	<p>H - Offset shank for I.D. threading &amp; shallow grooving</p>  <p>V - Offset shank for O.D. threading &amp; shallow grooving</p> 	<p>L - Left Hand</p>  <p>R - Right Hand</p> 	 <p>(I.C.) shown in 1/8 inch increments</p> <p>3 = 3/8 4 = 1/2 5 = 5/8</p>
---	---	--	---



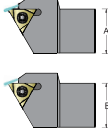

1. Bar Style      3. Tool Style      5. Hand of Tool      7. Insert Size I.C.

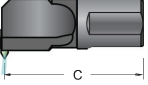

2. Insert Shape      4. Rake Attitude      6. Shank Size      8. Tool Length

<p>T - Triangle</p> 	<p>negative</p>  <p>neutral</p>  <p>positive</p> 	 <p>(A) &amp; (B) shown in 1/16 inch increments</p>	 <p>J- 3.5"      D- 6.0" A- 4.0"      E- 7.0" B- 4.5"      F- 8.0" C- 5.0"</p>
---	---	---	---



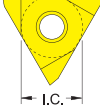

A.N.S.I. (American National Standards Institute)  
AS-16R-ADTHOR/L-3

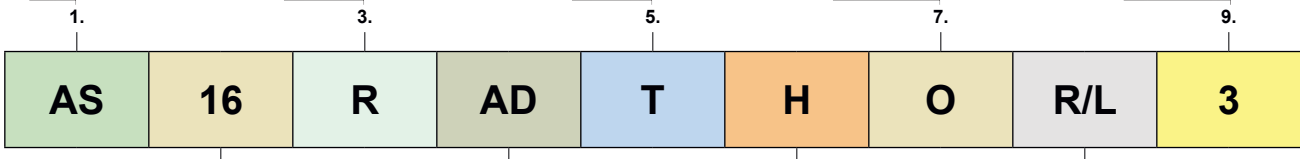
<p>AS - Steel With Coolant C - Carbide E - Carbide With Coolant S - Steel</p>	 <p>H - 4.0"      S - 10.0" J - 4.5"      T - 12.0" K - 5.0"      U - 14.0" M - 6.0"      V - 16.0" R - 8.0"      Y - 18.0"</p>	<p>T - Triangle</p> 	<p>N - Negative</p>  <p>O - Neutral</p>  <p>P - Positive</p> 	 <p>(I.C.) shown in 1/8 inch increments</p> <p>3 = 3/8      5 = 5/8 4 = 1/2</p>
---	--	---	---	--

1. Bar Type      3. Bar Length      5. Insert Shape      7. Rake Attitude      9. Insert Size I.C.

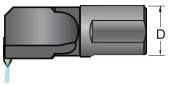

2. Bar Size      4. Bar Style      6. Tool Style      8. Hand of Tool

 <p>(D) shown in 1/16 inch increments</p>	<p>AD- Thru Coolant</p> 	<p>H - Offset shank for I.D. threading &amp; shallow grooving</p> 	<p>R - Right Hand      L - Left Hand</p>  
--	---	--	--

**ADTVO R Toolholder Style V - O.D. OnEdge Threading and shallow grooving for triangle TNMC inserts**

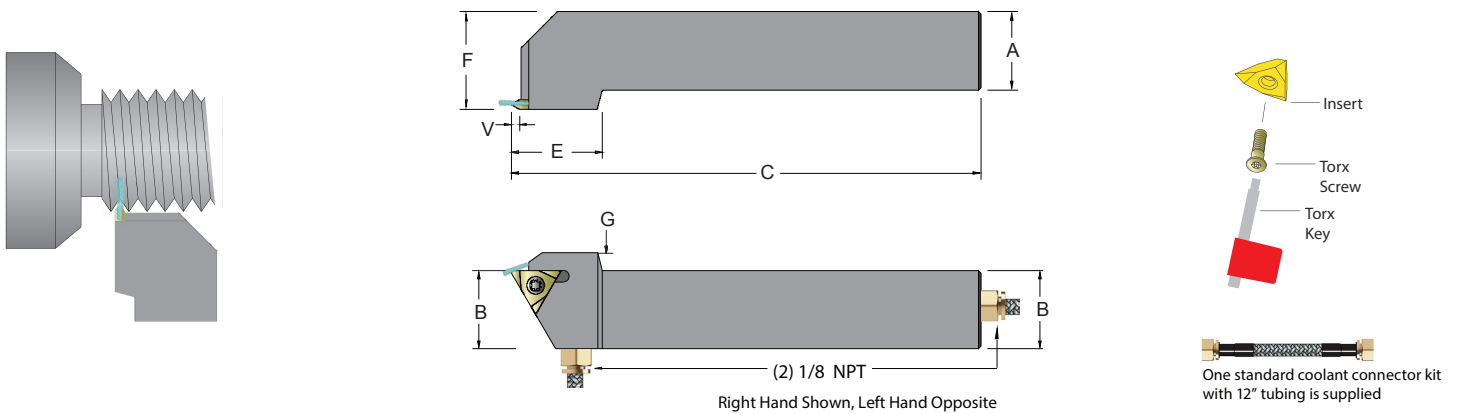

Inch Description	UPC No. 733101-R.H.	A	B	C	E	F	G	V	TNMC Gage Insert	Insert Torx Screw	Torx Key
ADTVOR12-3B	53400	0.75	0.75	4.50	1.02	0.88	0.13	0.15	322	GTS-1M	T-10
ADTVOR16-3D	53402	1.00	1.00	6.00	1.16	1.25	0.25	0.15			
ADTVOR12-4B	53404	0.75	0.75	4.50	1.25	0.88	0.13	0.23	432	GTS-2	T-20
ADTVOR16-4D	53406	1.00	1.00	6.00	1.25	1.25	0.13	0.23			
ADTVOR20-4D	53408	1.25	1.25	6.00	1.25	1.50	0.23	0.23			

One standard coolant connector kit with tubing is supplied, see page B-49 for details and high pressure coolant fitting. For OnEdge inserts see pages D-16 - D-19. For spare parts see page B-50.

**AS-ADTHO R/L Threading Bar Style H - I.D. OnEdge Threading and shallow grooving for triangle TNMC inserts**

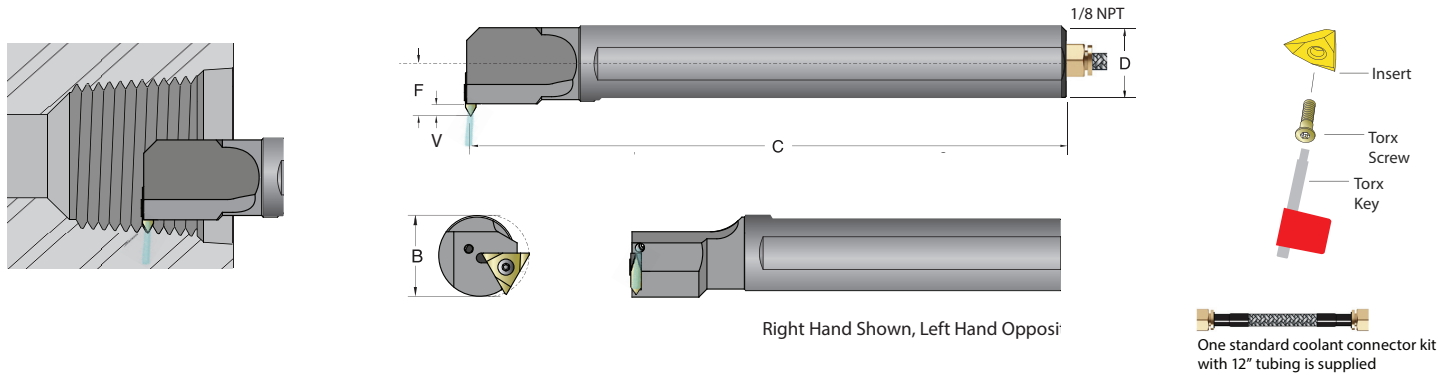

Inch Description	UPC No. 733101-R.H.	L.H.	B	C	D	F	V	TNMC Gage Insert	Insert Torx Screw	Torx Key	Chip Flush Plug
AS-16R-ADTHOR/L-3	53436	-	1.390	8.000	1.00	.6870	.120	322	GTS-1M	T-10	JSPN-M6
AS-20S-ADTHOR/L-4	53438	-	1.812	10.00	1.25	.8750	.190				
AS-32T-ADTHOR/L-4	53442	53443	3.000	12.00	2.00	1.328	.190	432	GTS-2	T-20	JSPN-M6

One standard coolant connector kit with tubing is supplied, see page B-49 for details and high pressure coolant fitting. For OnEdge inserts see pages D-16 - D-19. For spare parts see page B-50.

A.N.S.I. (American National Standards Institute)  
ADNSR/L16-4D

## DorNotch Identification System

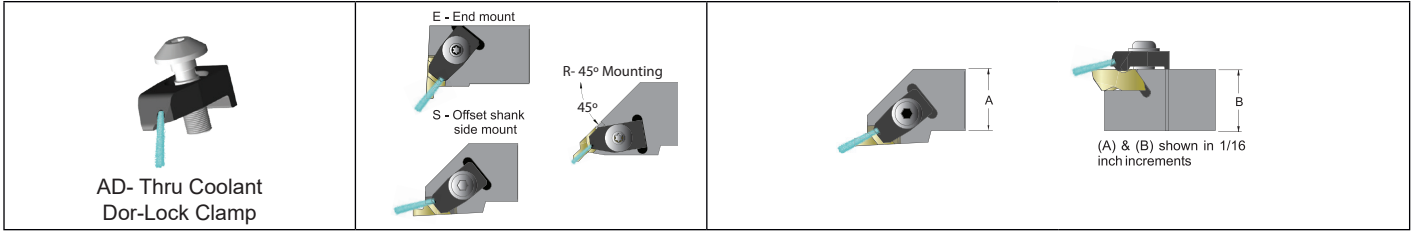

1. Clamp Style      3. Tool Style      5. Shank Size

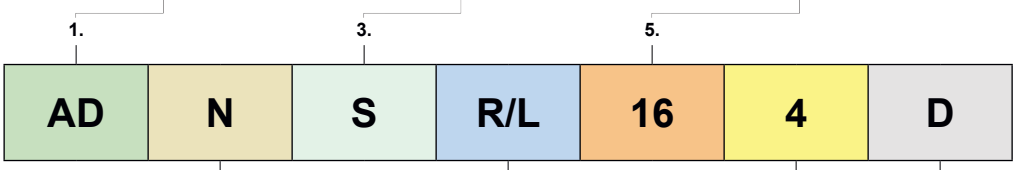

2. Insert Style      4. Hand of Tool      6. Insert Size I.C.      7. Tool Length

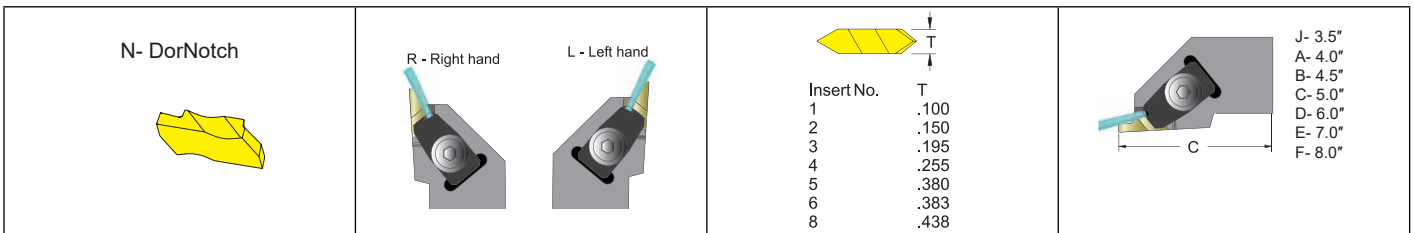

A.N.S.I. (American National Standards Institute)  
AS-16R-ADNER/L-3

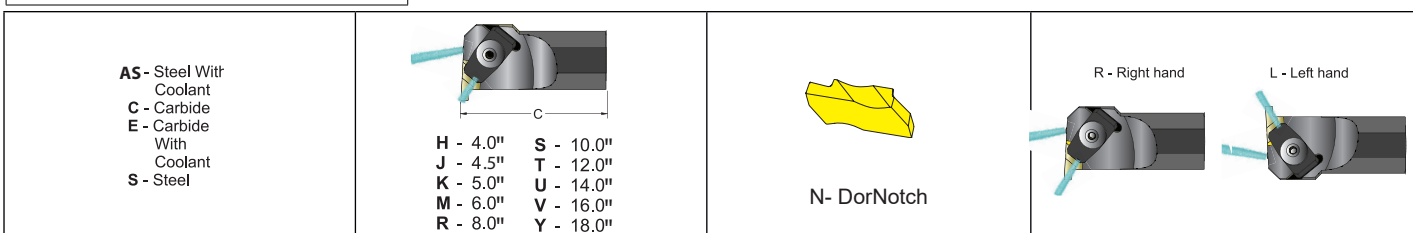

1. Bar Type      3. Bar Length      5. Insert Style      8. Insert Size I.C.

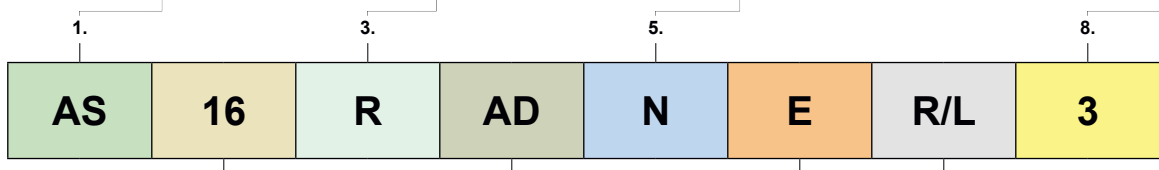

2. Bar Size      4. Clamp Style      6. Tool Style      7. Hand of Tool

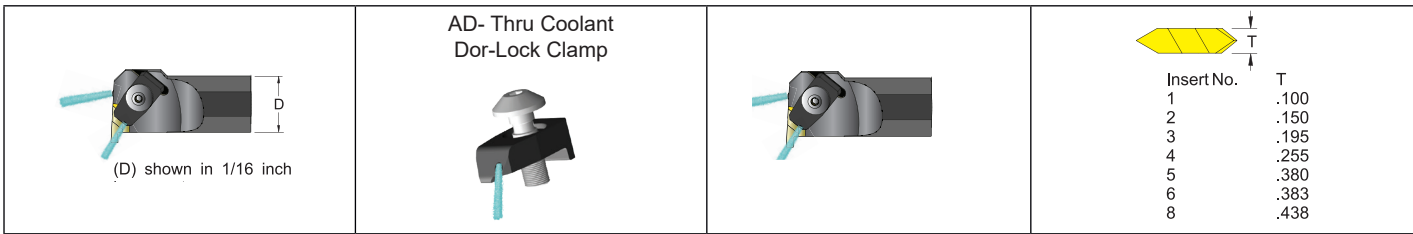



**ADNS R/L Toolholder Style S - External DorNotch toolholder for threading and grooving DorNotch inserts**

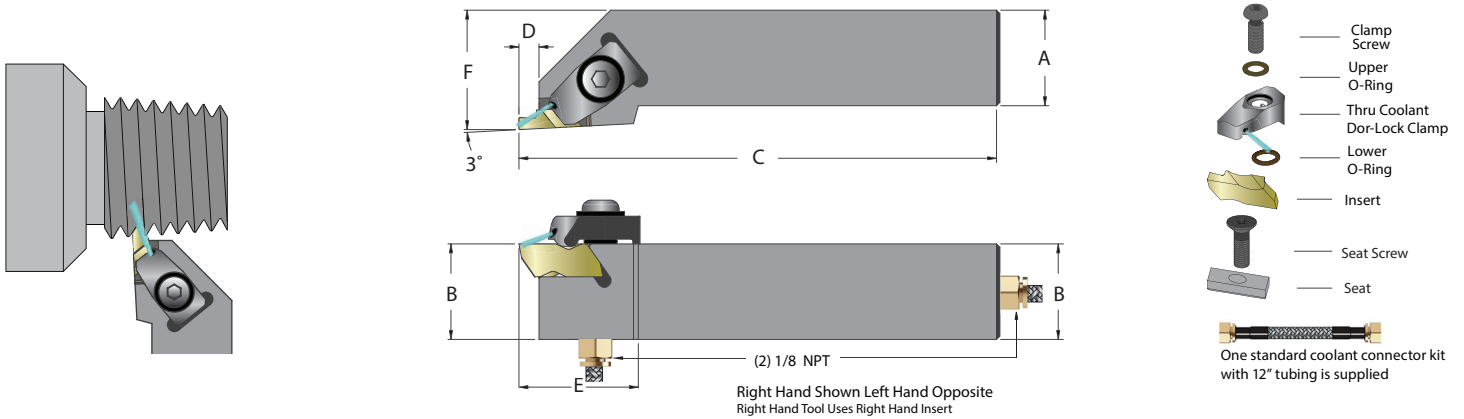

Inch Description	UPC No. 733101-		A	B	C	D	E	F	Gage Insert	Seat	Seat Screw	Dor-Lock Clamp	Clamp Screw	Upper 'O' Ring	Lower 'O' Ring	
	R.H.	L.H.														
ADNSR/L12-3B	53450	53451	0.75	0.75	4.50	0.21	1.25	1.00								
ADNSR/L16-3D	53452	53453	1.00	1.00	6.00	0.21	1.25	1.25	* NG-3R ** NG-3L	N/A	N/A	* JSLC-HP72 ** JSLC-HP73	JSCS-04	JSOR-01	JSOR-08	
ADNSR/L20-3D	53454	53455	1.25	1.25	6.00	0.21	1.25	1.50								
ADNSR/L16-4D	53456	53457	1.00	1.00	6.00	0.29	1.38	1.25								
ADNSR/L20-4D	53458	53459	1.25	1.25	6.00	0.29	1.38	1.50	* NG-4R ** NG-4L	SM-420	SL-344	* JSLC-HP76 ** JSLC-HP77	JSCS-04	JSOR-01	JSOR-08	
ADNSR/L24-4E	53460	53461	1.50	1.50	7.00	0.29	1.38	1.75								

One standard coolant connector kit with tubing is supplied, see page B-49 for details and high pressure coolant fitting. For DorNotch inserts see pages D-30 - D-35. For spare parts see page B-50. \*For right hand tool. \*\*For left hand tool.

**ADNE R/L Toolholder Style E- Gang external DorNotch toolholder for threading and grooving DorNotch inserts**

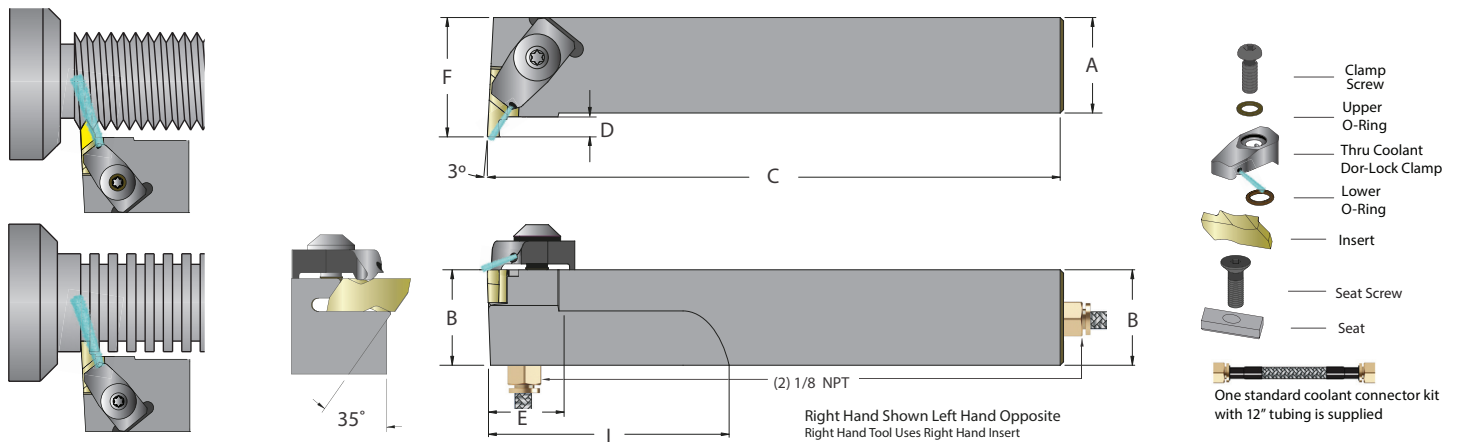

Inch Description	UPC No. 733101-		A	B	C	D	E	F	I	Gage Insert	Dor-Lock Clamp	Clamp Screw	Upper 'O' Ring	Lower 'O' Ring
	R.H.	L.H.												
ADNER/L12-3B	53465	53466	0.75	0.75	4.50	0.21	0.75	1.13	2.00					
ADNER/L16-3D	53467	53468	1.00	1.00	6.00	0.21	0.75	1.25	2.00	* NG-3L ** NG-3R	* JSLC-HP73 ** JSLC-HP72	JSCS-08	JSOR-01	JSOR-08
ADNER/L20-3D	53469	53470	1.25	1.25	6.00	0.21	0.75	1.50	2.00					
ADNER/L16-4D	53471	53472	1.00	1.00	6.00	0.29	0.75	1.38	2.00					
ADNER/L20-4D	53473	53474	1.25	1.25	6.00	0.29	0.75	1.63	2.00	* NG-4L ** NG-4R	* JSLC-HP77 ** JSLC-HP76	JSCS-08	JSOR-01	JSOR-08

One standard coolant connector kit with tubing is supplied, see page B-49 for details and high pressure coolant fitting. For DorNotch inserts see pages D-30 - D-35. For spare parts see page B-50. \*For right hand tool. \*\*For left hand tool.

**AS-ADNE R/L Threading Bar Style E- Internal DorNotch Bar for threading and grooving DorNotch inserts**

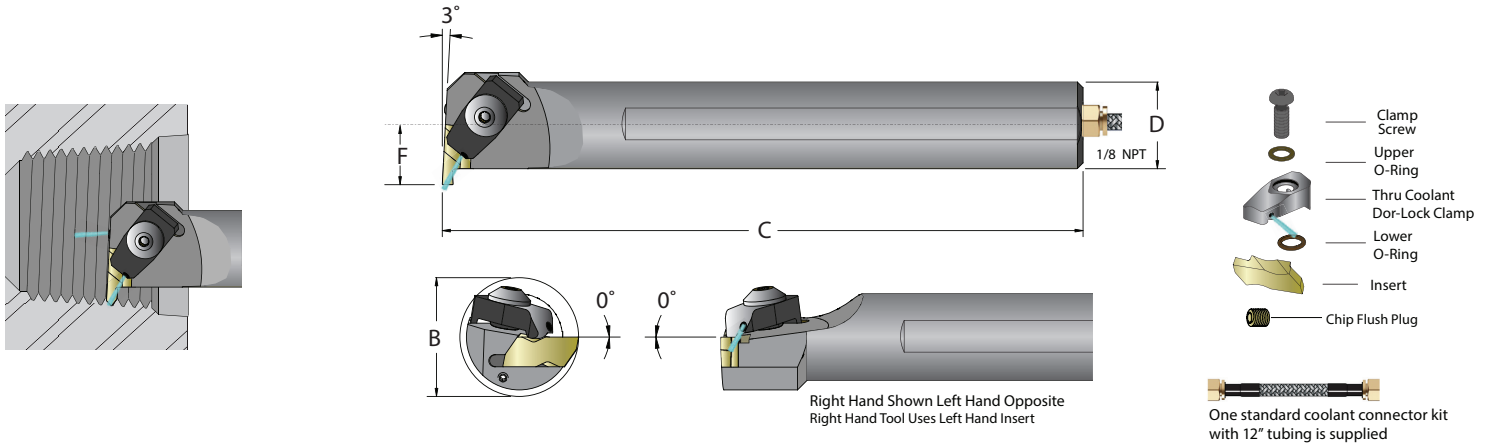

Inch Description	UPC No. 733101-		B	C	D	F	Gage Insert	Dor-Lock Clamp	Clamp Screw	Upper 'O' Ring	Lower 'O' Ring	Chip Flush Plug
	R.H.	L.H.										
AS-16R-ADNER/L-3	53490	53491	1.38	8.00	1.00	0.69						
AS-20S-ADNER/L-3	53492	53493	1.75	10.00	1.25	0.88	* NG-3L ** NG-3R	* JSLC-HP73 ** JSLC-HP72	JSCS-08	JSOR-01	JSOR-08	JSPN-M6
AS-24S-ADNER/L-3	53494	53495	2.00	10.00	1.50	1.00						
AS-32T-ADNER/L-4	53496	53497	2.75	12.00	2.00	1.38	* NG-4L ** NG-4R	* JSLC-HP73 ** JSLC-HP72	JSCS-08	JSOR-01	JSOR-08	JSPN-M6

One standard coolant connector kit with tubing is supplied, see page B-49 for details and high pressure coolant fitting. For DorNotch inserts see pages D-30 - D-35. For spare parts see page B-50. \*For right hand tool. \*\*For left hand tool.

A.N.S.I. (American National Standards Institute) ADLER/L12-16C I.S.O. (International Standards Organization) ADLERL2020-16K **Laydown Identification System**

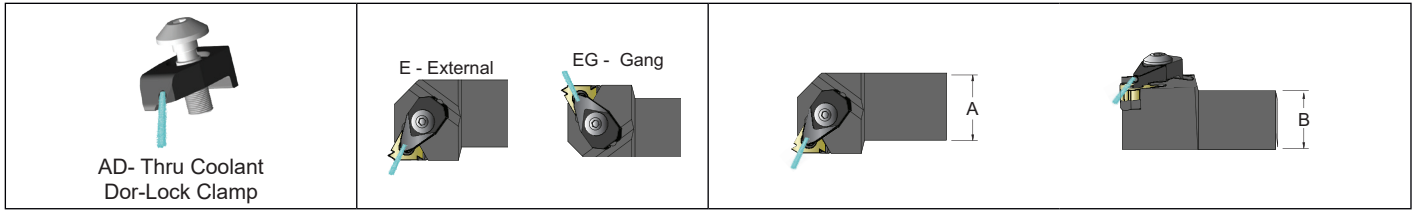

1. Clamp Style      3. Tool Style      5. Shank Size

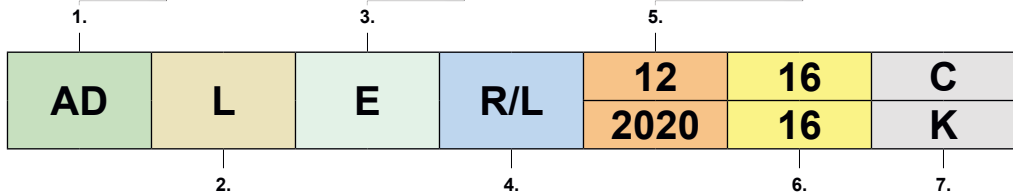

2. Insert Style      4. Hand of Tool      6. Insert Size      7. Tool Length

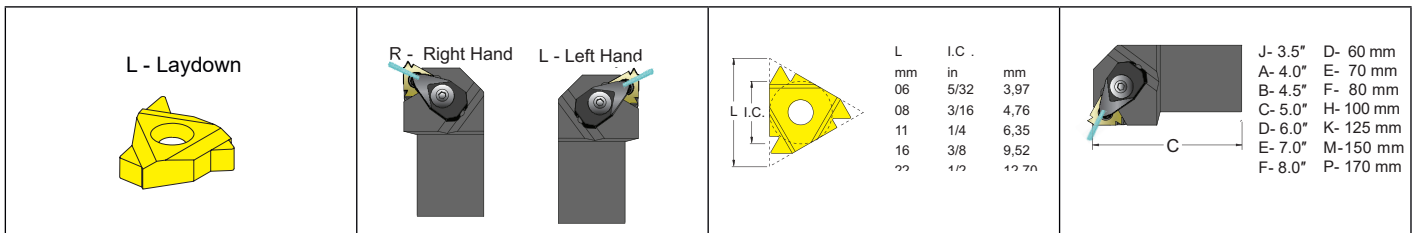

A.N.S.I. (American National Standards Institute) AS-12R-ADLNR/L-16 I.S.O. (International Standards Organization) AS-20R-ADLNR/L-16

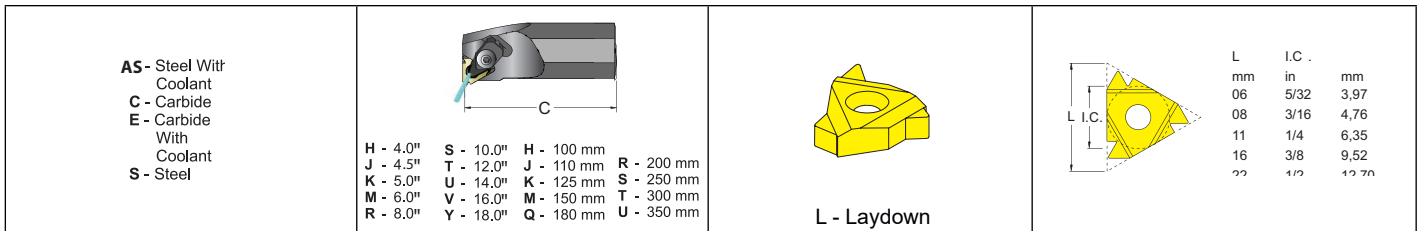

1. Bar Type      3. Bar Length      5. Insert Style      8. Insert Size

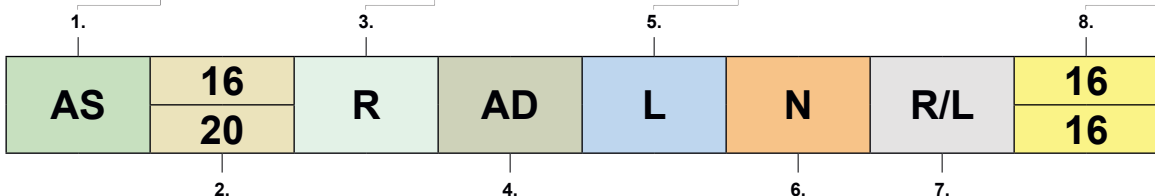

2. Bar Size      4. Clamp Style      6. Tool Style      7. Hand of Tool

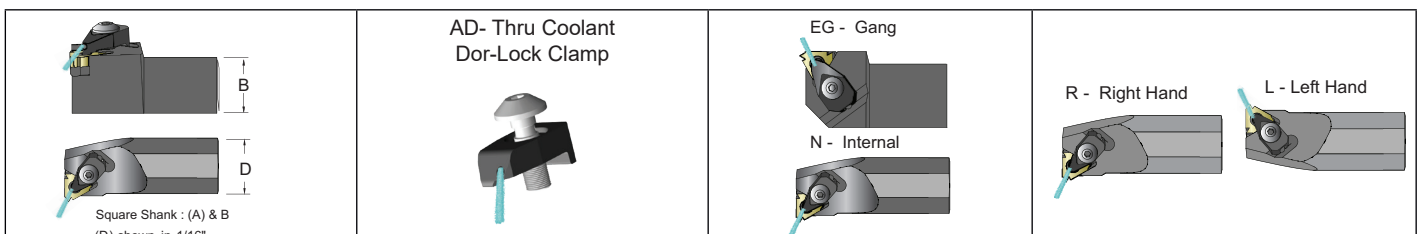

**ADLE R/L Toolholder Style E- Laydown toolholder for Laydown inserts**

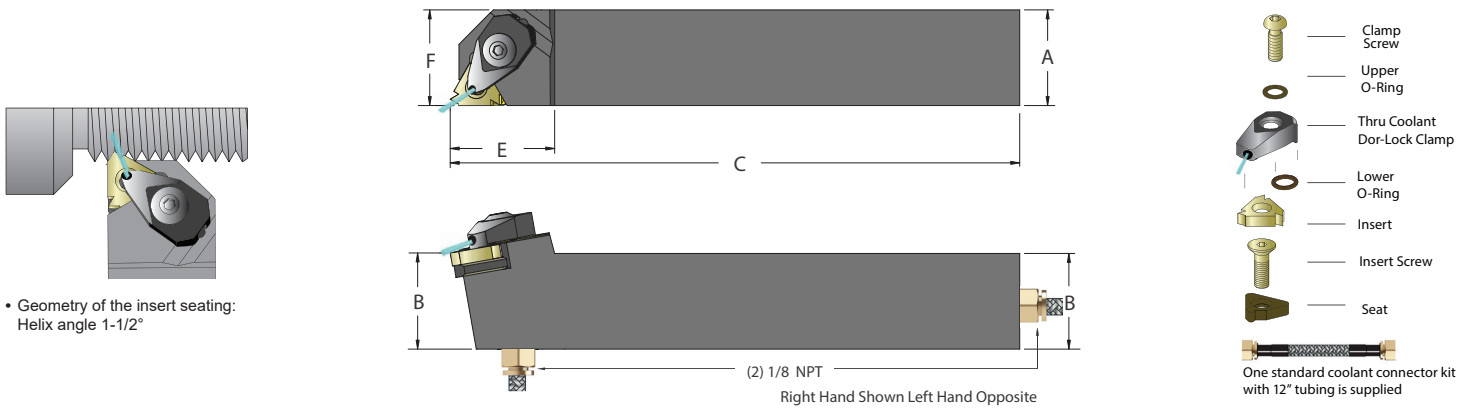

Inch Description	UPC No. 733101-		A	B	C	E	F	Gage	Insert Screw	Dor-Lock Clamp	Clamp Screw	Upper 'O' Ring	Lower 'O' Ring	
	R.H.	L.H.						Insert						Seat
ADLER/L12-16C	53510	-	0.75	0.75	5.00	1.25	0.75	16-G60	GXE/1-16	TS-35.6-14M1	*JSLC-HP16R-N *JSLC-HP16L-N	JSCS-03	JSOR-03	JSOR-06
ADLER/L16-16D	53512	53513	1.00	1.00	6.00	1.25	1.00							

One standard coolant connector kit with tubing is supplied, see page B-49 for details and high pressure coolant fitting. For Laydown inserts see pages E-20 - E-29. For spare parts see page B-50.  
 \*Right hand toolholder use a right hand clamp and Left hand toolholder use a left hand clamp.

**ADLE R/L Qualified Toolholder Style E - Offset head for Laydown inserts**

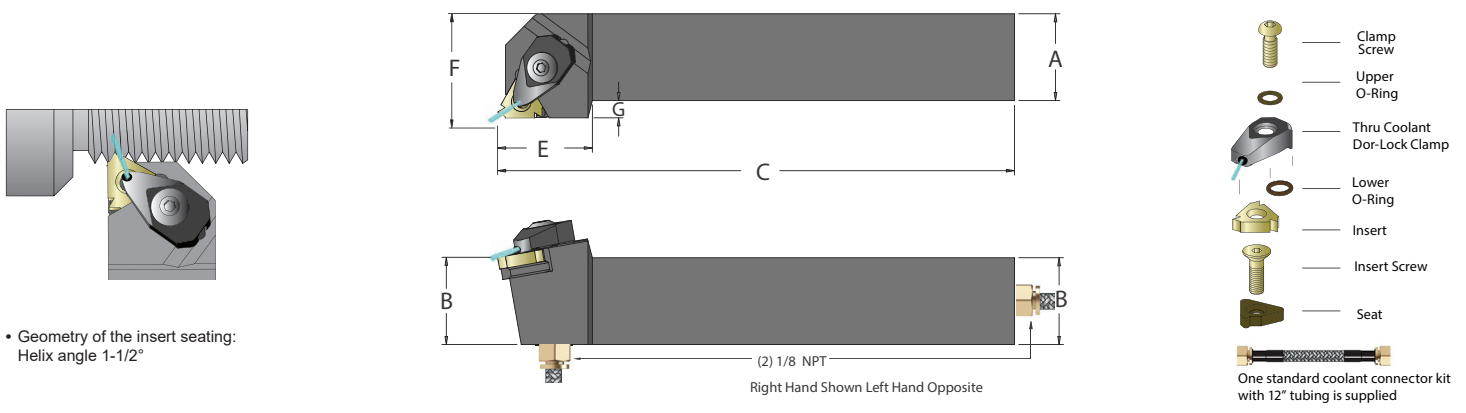

Inch Description	UPC No. 733101-		A	B	C	E	F	G	Gage	Insert Screw	Dor-Lock Clamp	Clamp Screw	Upper 'O' Ring	Lower 'O' Ring	
	R.H.	L.H.							Insert						Seat
ADLER/L12-16Q-C	53522	-	0.75	0.75	5.00	1.25	1.00	0.25	16-G60	GXE/1-16	TS-35.6-14M1	*JSLC-HP16R-N *JSLC-HP16L-N	JSCS-03	JSOR-03	JSOR-06
ADLER/L16-16Q-D	53524	53525	1.00	1.00	6.00	1.25	1.25	0.25							
ADLER/L16-22Q-D	53528	-	1.00	1.00	6.00	1.50	1.25	0.25	22-N60	NXE/1-16	TS-45.75-15M1	JSLC-HP22N	JSCS-04	JSOR-01	JSOR-04
ADLER/L20-22Q-E	53530	-	1.25	1.25	6.00	1.50	1.50	0.25							

One standard coolant connector kit with tubing is supplied, see page B-49 for details and high pressure coolant fitting. For Laydown inserts see pages E-20 - E-29. For spare parts see page B-50.  
 \*Right hand toolholder use a right hand clamp and Left hand toolholder use a left hand clamp.



**AS-ADLN R/L Threading Bar Style N - Internal Laydown bar for Laydown threading**

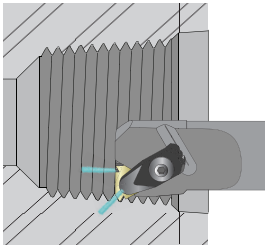

- Minimum threading diameter .112"
- Geometry of the insert seating:  
Helix angle 1-1/2°

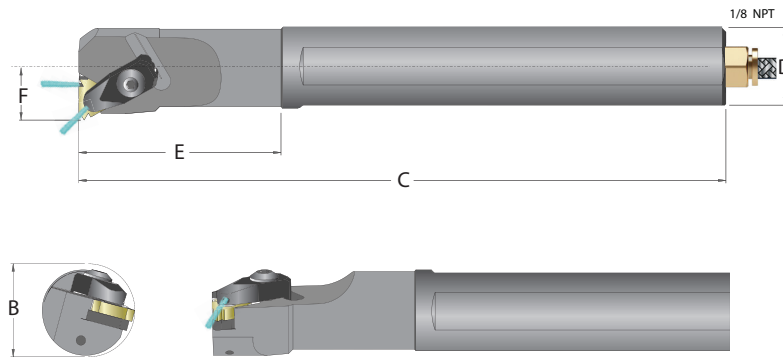

Right Hand Shown, Left Hand Opposite

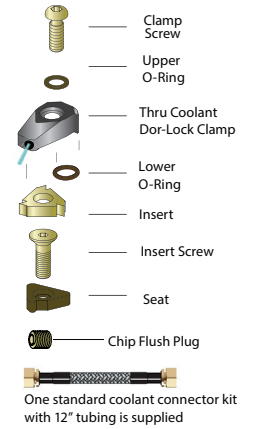

Inch Description	UPC No. 733101-		Min. Bore					Gage Insert	Seat	Insert Screw	Dor-Lock Clamp	Clamp Screw	Upper 'O' Ring	Lower 'O' Ring	Chip Flush Plug
	R.H.	L.H.	B	C	D	E	F								
AS-12R-ADLNR/L-16	53533	53534	1.12	8.00	0.75	2.00	.52	16-G60	GXE/1-16	TS-35.6-14M1	*JSLC-HP16R-N *JSLC-HP16L-N	JSCS-03	JSOR-03	JSOR-06	JSPN-M3
AS-16R-ADLNR/L-16	53535	53536	1.37	8.00	1.00	2.50	.65								
AS-20S-ADLNR/L-16	53537	53538	1.62	10.00	1.25	2.50	.78								
AS-24S-ADLNR/L-16	53539	53540	1.87	10.00	1.50	2.50	.90								
AS-24S-ADLNR/L-22	53543	-	2.00	10.00	1.50	2.50	1.25	22-N60	GXE/1-16	TS-45.75-15M1	JSLC-HP22N	JSCS-04	JSOR-01	JSOR-04	JSPN-M6
AS-32T-ADLNR/L-22	53545	53546	2.50	12.00	2.00	2.50	1.50								

One standard coolant connector kit with tubing is supplied, see page B-49 for details and high pressure coolant fitting. For Laydown inserts see pages E-20 - E-29. For spare parts see page B-50. \*Right hand bars use a left hand clamp and Left hand bars use a right hand clamp.

**ADCLN R/L Toolholder Style L - 5° end or side cutting lead angle for negative 80° diamond CNM\_inserts**

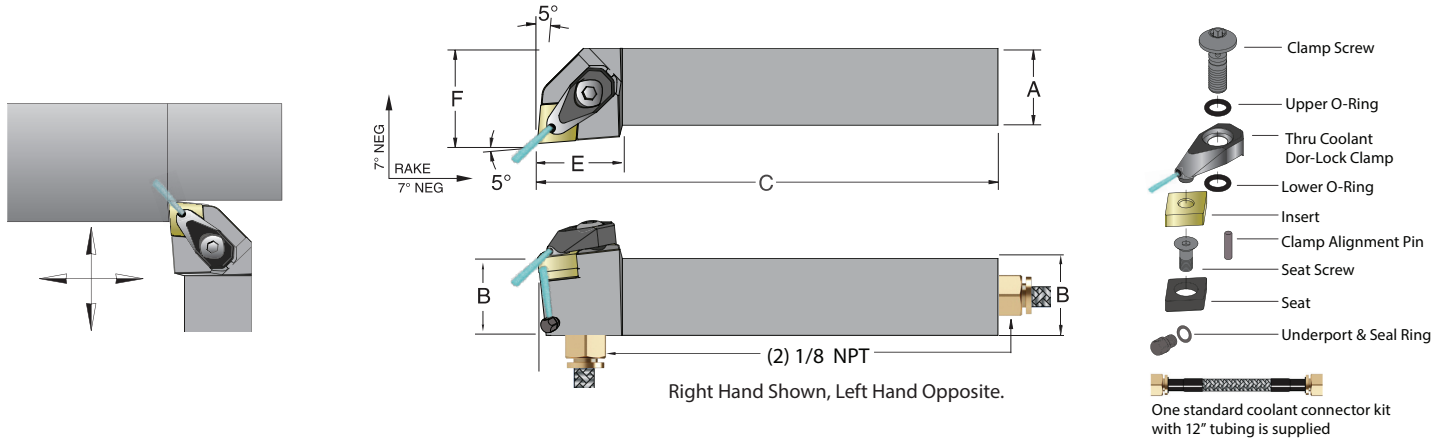

Metric Description	UPC No. 733101-		A	B	C	E	F	CNM_		Seat Screw	Dor-Lock Clamp	Clamp Screw	Upper 'O' Ring	Lower 'O' Ring
	R.H.	L.H.						Gage Insert	Seat					
ADCLNR/L-2020-K12	52828	52829	20	20	125	32	25	120408	JC-432	SM-S4	JSLC-HPCTW-4N	JSCS-04	JSOR-01	JSOR-04
ADCLNR/L-2525-M12	52830	52831	25	25	150	32	32	120408	JC-432	SM-S4	JSLC-HPCTW-4N	JSCS-04	JSOR-01	JSOR-04
ADCLNR/L-3232-P12	52832	52833	32	32	170	32	40	120408	JC-432	SM-S4	JSLC-HPCTW-4N	JSCS-04	JSOR-01	JSOR-04
ADCLNR/L-3232-P16	52834	52835	32	32	170	35	40	160612	JC-533	SM-M6	JSLC-HPC5	JSCS-04	JSOR-01	JSOR-04
ADCLNR/L-4040-S12	52836	52837	40	40	250	32	50	120408	JC-432	SM-S4	JSLC-HPCTW-4N	JSCS-04	JSOR-01	JSOR-04
ADCLNR/L-4040-S16	52838	52839	40	40	250	35	50	160612	JC-533	SM-M6	JSLC-HPC5	JSCS-04	JSOR-01	JSOR-04

\*Special Order, available upon request. One standard coolant connector kit with tubing is supplied, see page B-49 for details and high pressure coolant fitting. For Turning inserts see Sect.A. For spare parts see page B-50.

**ADDJN R/L Toolholder Style J - 3° side cutting lead angle for negative 55° diamond DNM\_inserts**

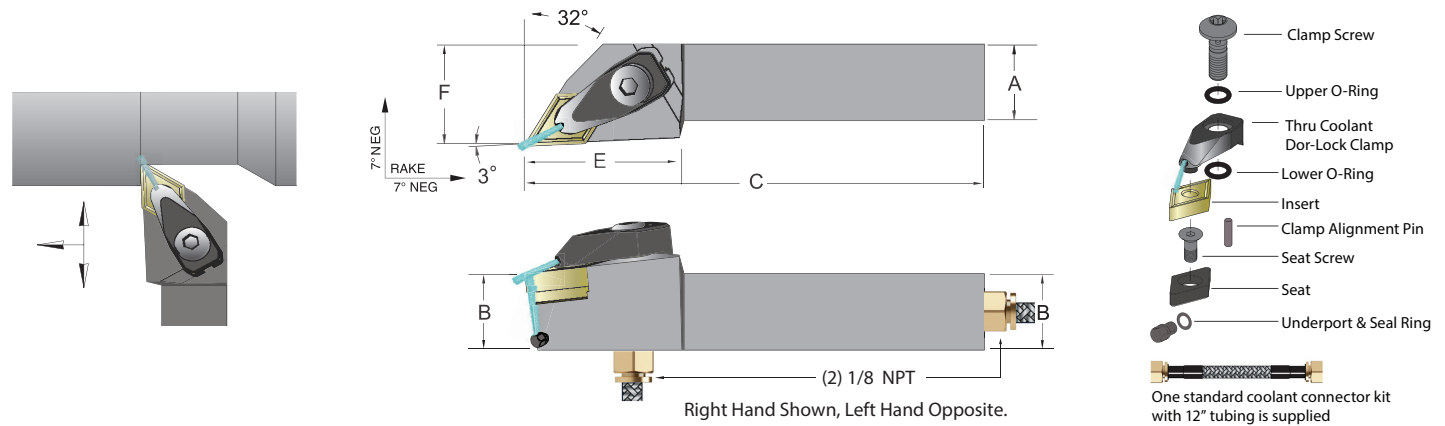

Metric Description	UPC No. 733101-		A	B	C	E	F	DNM_		Seat Screw	Dor-Lock Clamp	Clamp Screw	Upper 'O' Ring	Lower 'O' Ring
	R.H.	L.H.						Gage Insert	Seat					
ADDJNR/L-2020-K11	52842	52843	20	20	125	38	25	110408	IDSN-322	SM-M4-245	JSLC-HPD3	JSCS-04	JSOR-01	JSOR-04
ADDJNR/L-2020-K15	52844	52845	20	20	125	38	25	150608	IDSN-423	SM-S4	JSLC-HPD4	JSCS-04	JSOR-01	JSOR-04
ADDJNR/L-2525-M15	52846	52847	25	25	150	38	32	150608	IDSN-423	SM-S4	JSLC-HPD4	JSCS-04	JSOR-01	JSOR-04
ADDJNR/L-3232-P15	52848	52849	32	32	170	38	38	150608	IDSN-423	SM-S4	JSLC-HPD4	JSCS-04	JSOR-01	JSOR-04
*ADDJNR/L-4040-S15	52850	52851	40	40	250	38	50	150608	IDSN-423	SM-S4	JSLC-HPD4	JSCS-04	JSOR-01	JSOR-04

\*Special Order, available upon request. One standard coolant connector kit with tubing is supplied, see page B-49 for details and high pressure coolant fitting. For Turning inserts see Sect.A. For spare parts see page B-50.

**ADDPNN Toolholder Style P - 27.5° side cutting lead angle for negative 55° diamond DNM\_inserts**

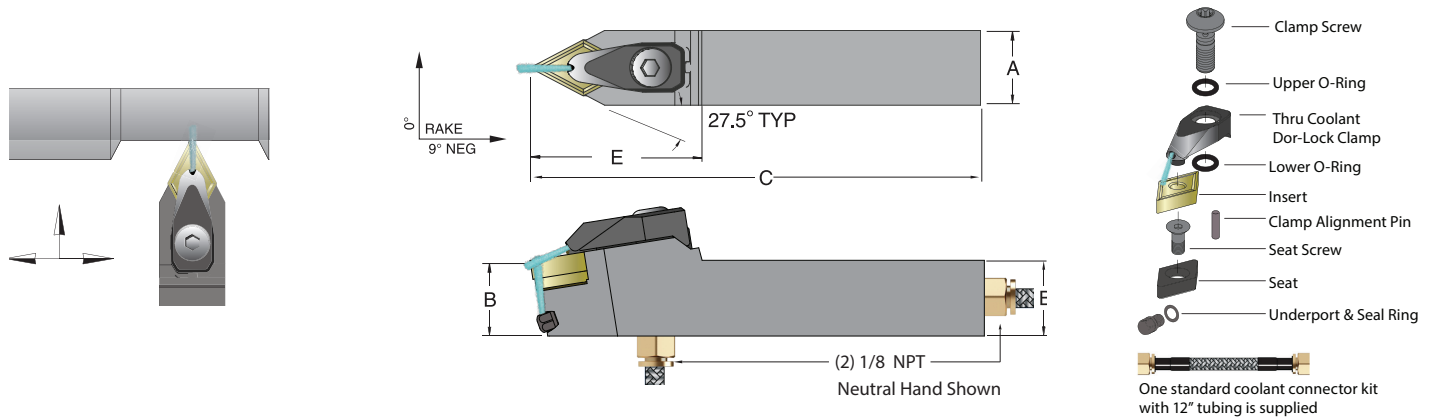

Metric Description	UPC No. 733101-Neutral	A	B	C	E	DNM_Gage Insert	Seat	Seat Screw	Dor-Lock Clamp	Clamp Screw	Upper 'O' Ring	Lower 'O' Ring
ADDPNN-2020-K11	52854	20	20	125	44	110408	IDSN-322	SM-M4-245	JSLC-HPD3	JSCS-04	JSOR-01	JSOR-04
ADDPNN-2020-K15	52855	20	20	125	44	150608	IDSN-423	SM-S4	JSLC-HPD4	JSCS-04	JSOR-01	JSOR-04
ADDPNN-2525-M11	52856	25	25	150	44	110408	IDSN-322	SM-M4-245	JSLC-HPD3	JSCS-04	JSOR-01	JSOR-04
ADDPNN-2525-M15	52857	25	25	150	44	150608	IDSN-423	SM-S4	JSLC-HPD4	JSCS-04	JSOR-01	JSOR-04
ADDPNN-3232-P15	52858	32	32	170	44	150608	IDSN-423	SM-S4	JSLC-HPD4	JSCS-04	JSOR-01	JSOR-04
*ADDPNN-4040-S15	52859	40	40	250	44	150608	IDSN-423	SM-S4	JSLC-HPD4	JSCS-04	JSOR-01	JSOR-04

\*Special Order, available upon request. One standard coolant connector kit with tubing is supplied, see page B-49 for details and high pressure coolant fitting. For Turning inserts see Sect.A. For spare parts see page B-50.

**ADSDNN Toolholder Style D - 45° side cutting lead angle for negative square SNM\_inserts**

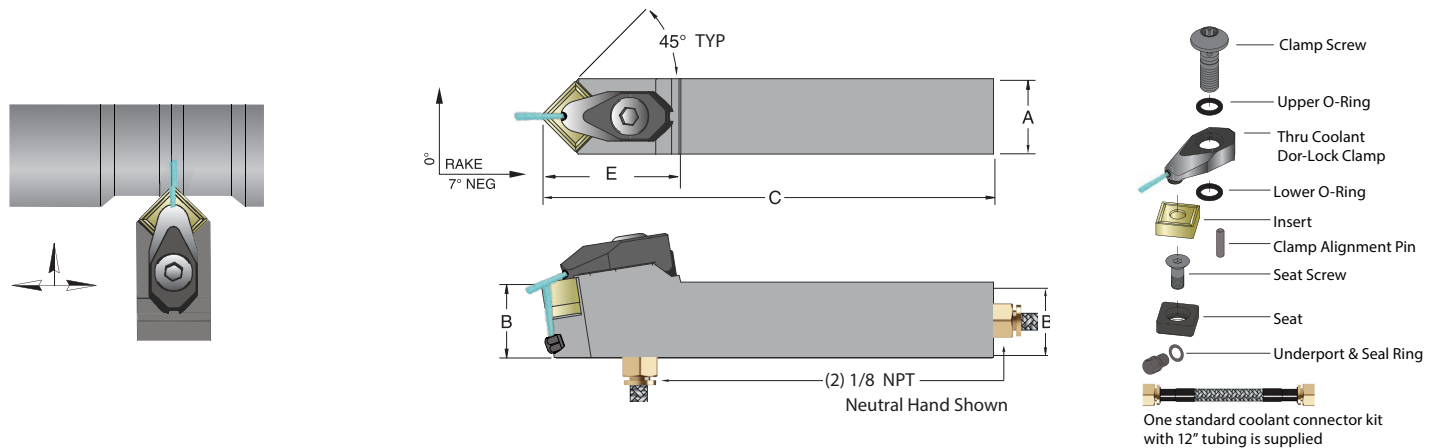

Metric Description	UPC No. 733101-Neutral	A	B	C	E	SNM_Gage Insert	Seat	Seat Screw	Dor-Lock Clamp	Clamp Screw	Upper 'O' Ring	Lower 'O' Ring
ADSDNN-2525-M12	52872	25	25	150	35	120408	ISSN-423	SM-S4	JSLC-HPCTW-4N	JSCS-04	JSOR-01	JSOR-04
ADSDNN-3232-P12	52873	32	32	170	35	120408	ISSN-423	SM-S4	JSLC-HPCTW-4N	JSCS-04	JSOR-01	JSOR-04
ADSDNN-3232-P15	52874	32	32	170	35	150612	JS-533	SM-M6	JSLC-HPC5	JSCS-04	JSOR-01	JSOR-04
*ADSDNN-4040-S15	52875	40	40	250	35	150612	JS-533	SM-M6	JSLC-HPC5	JSCS-04	JSOR-01	JSOR-04

\*Special Order, available upon request. One standard coolant connector kit with tubing is supplied, see page B-49 for details and high pressure coolant fitting. For Turning inserts see Sect.A. For spare parts see page B-50.

**ADSRN R/L Toolholder Style R - 15° side cutting lead angle for negative square SNM\_inserts**

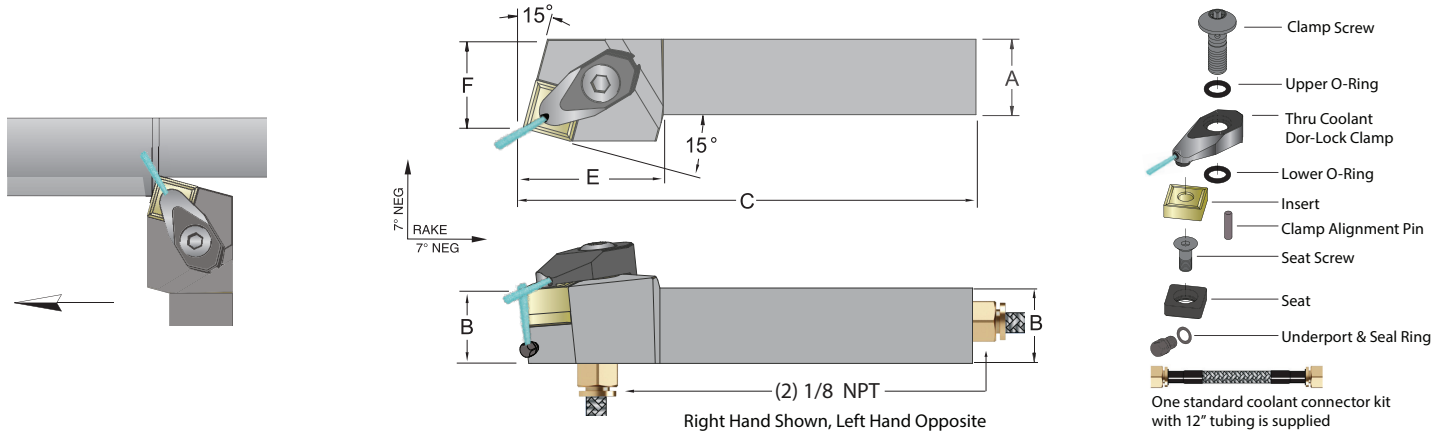

Metric Description	UPC No. 733101-		A	B	C	E	F	SNM_ Gage Insert	Seat	Seat Screw	Dor-Lock Clamp	Clamp Screw	Upper 'O' Ring	Lower 'O' Ring
	R.H.	L.H.												
ADSRNR/L-2020-K12	52862	52863	20	20	125	35	21	120408	ISSN-423	SM-S4	JSLC-HPCTW-4N	JSCS-04	JSOR-01	JSOR-04
ADSRNR/L-2525-M12	52864	52865	25	25	150	35	25	120408	ISSN-423	SM-S4	JSLC-HPCTW-4N	JSCS-04	JSOR-01	JSOR-04
ADSRNR/L-3232-P15	52866	52867	32	32	170	35	25	150612	JS-533	SM-M6	JSLC-HPC5	JSCS-04	JSOR-01	JSOR-04
*ADSRNR/L-4040-S15	52868	52869	40	40	250	40	25	150612	JS-533	SM-M6	JSLC-HPC5	JSCS-04	JSOR-01	JSOR-04

\*Special Order, available upon request. One standard coolant connector kit with tubing is supplied, see page B-49 for details and high pressure coolant fitting. For Turning inserts see Sect.A. For spare parts see page B-50.

**ADTENN Toolholder Style E - 30° side cutting lead angle for negative triangle TNM\_inserts**

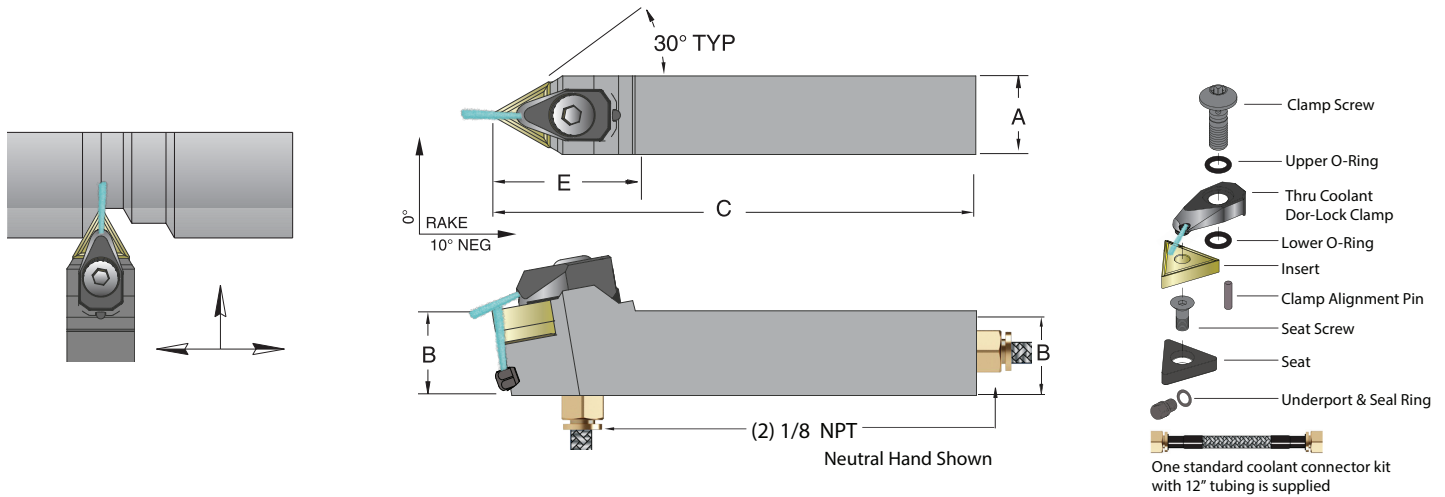

Metric Description	UPC No. 733101-	A	B	C	E	TNM_ Gage Insert	Seat	Seat Screw	Dor-Lock Clamp	Clamp Screw	Upper 'O' Ring	Lower 'O' Ring
	Neutral											
ADTENN-2020-K16	52892	20	20	125	35	160408	JT-322	SM-M3-T	JSLC-HPTW3N	JSCS-04	JSOR-01	JSOR-04
ADTENN-2020-K22	52893	20	20	125	35	220408	JT-433	SM-S4	JSLC-HPCTW-4N	JSCS-04	JSOR-01	JSOR-04
ADTENN-2525-M16	52894	25	25	150	35	160408	JT-322	SM-M3-T	JSLC-HPTW3N	JSCS-04	JSOR-01	JSOR-04
ADTENN-2525-M22	52895	25	25	150	35	220408	JT-433	SM-S4	JSLC-HPCTW-4N	JSCS-04	JSOR-01	JSOR-04
ADTENN-3232-P22	52896	32	32	170	40	220408	JT-433	SM-S4	JSLC-HPCTW-4N	JSCS-04	JSOR-01	JSOR-04
*ADTENN-4040-S22	52897	40	40	250	40	220408	JT-433	SM-S4	JSLC-HPCTW-4N	JSCS-04	JSOR-01	JSOR-04

\*Special Order, available upon request. One standard coolant connector kit with tubing is supplied, see page B-49 for details and high pressure coolant fitting. For Turning inserts see Sect.A. For spare parts see page B-50.



**ADTJN R/L Toolholder Style J - 3° side cutting lead angle for negative triangle TNM\_ inserts**

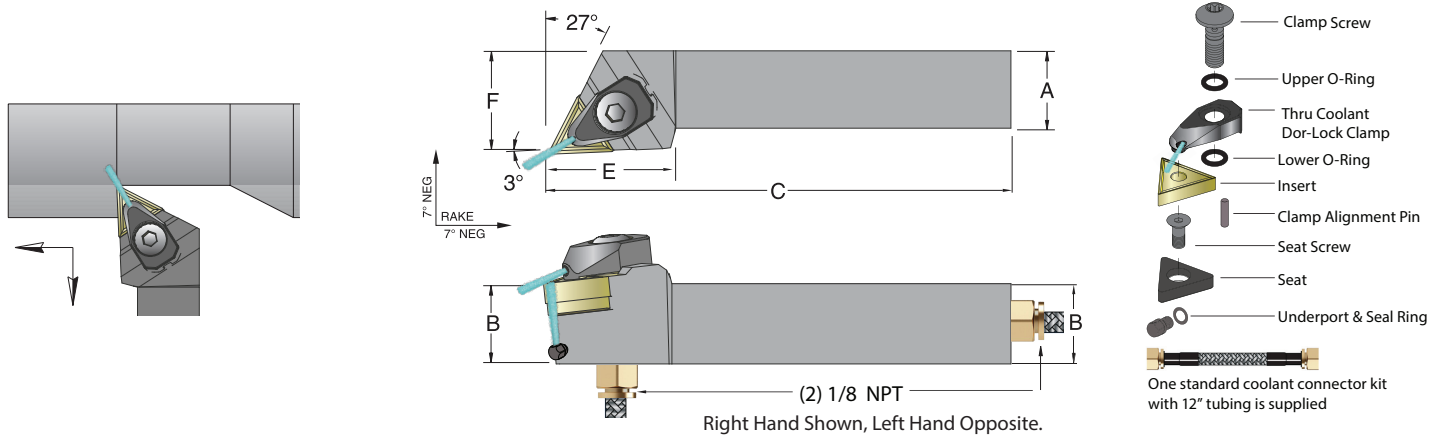

Metric Description	UPC No. 733101-		A	B	C	E	F	TNM_ Gage Insert	Seat	Seat Screw	Dor-Lock Clamp	Clamp Screw	Upper 'O' Ring	Lower 'O' Ring
	R.H.	L.H.												
ADTJNR/L-2020-K16	52878	52879	20	20	125	35	25	160408	JT-322	SM-M3-T	JSLC-HPTW3N	JSCS-04	JSOR-01	JSOR-04
ADTJNR/L-2020-K22	52880	52881	20	20	125	32	32	220408	JT-433	SM-S4	JSLC-HPCTW-4N	JSCS-04	JSOR-01	JSOR-04
ADTJNR/L-2525-M16	52882	52883	25	25	150	35	38	160408	JT-322	SM-M3-T	JSLC-HPTW3N	JSCS-04	JSOR-01	JSOR-04
ADTJNR/L-2525-M22	52884	-	25	25	150	35	50	220408	JT-433	SM-S4	JSLC-HPCTW-4N	JSCS-04	JSOR-01	JSOR-04
ADTJNR/L-3232-P22	52886	52887	32	32	170	32	50	220408	JT-433	SM-S4	JSLC-HPCTW-4N	JSCS-04	JSOR-01	JSOR-04
*ADTJNR/L-4040-S22	52888	25889	40	40	250	35	50	220408	JT-433	SM-S4	JSLC-HPCTW-4N	JSCS-04	JSOR-01	JSOR-04

\*Special Order, available upon request. One standard coolant connector kit with tubing is supplied, see page B-49 for details and high pressure coolant fitting. For Turning inserts see Sect.A. For spare parts see page B-50.

**ADVJN R/L Toolholder Style J - Negative 3° side cutting lead angle for negative 35° diamond VNM\_ inserts**

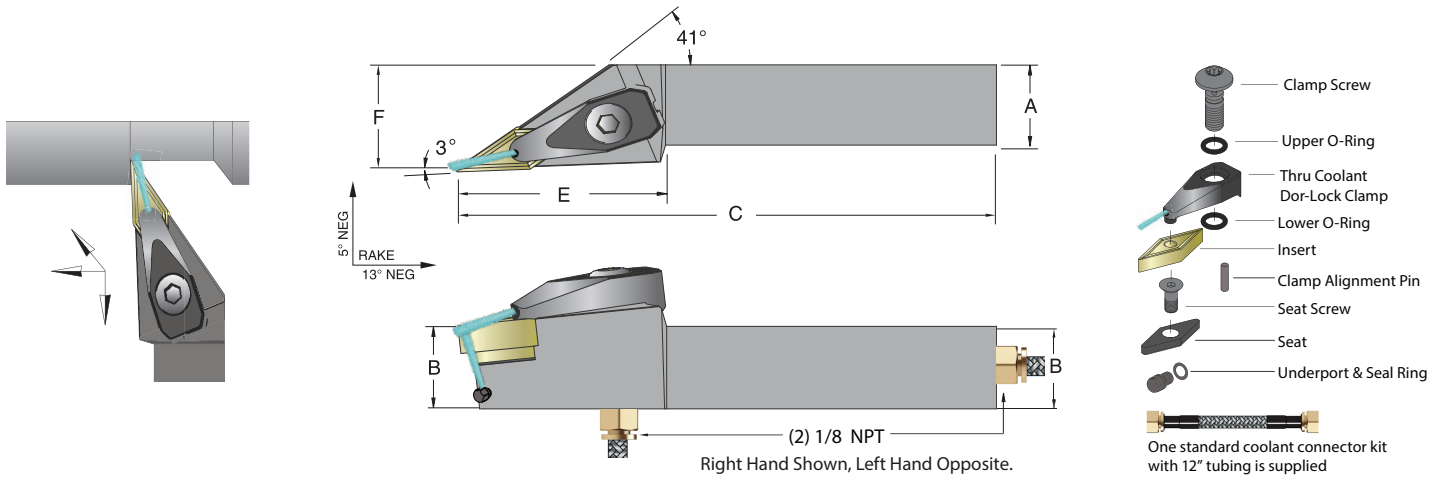

Metric Description	UPC No. 733101-		A	B	C	E	F	VNM_ Gage Insert	Seat	Seat Screw	Dor-Lock Clamp	Clamp Screw	Upper 'O' Ring	Lower 'O' Ring
	R.H.	L.H.												
ADVJNR/L-2020-K16	52900	52901	20	20	125	45	25	160408	JV-322	SM-M3	JSLC-HPV3	JSCS-04	JSOR-01	JSOR-04
ADVJNR/L-2525-M16	52902	52903	25	25	150	45	32	160408	JV-322	SM-M3	JSLC-HPV3	JSCS-04	JSOR-01	JSOR-04
ADVJNR/L-3232-P16	52904	52905	32	32	170	45	38	160408	JV-322	SM-M3	JSLC-HPV3	JSCS-04	JSOR-01	JSOR-04

One standard coolant connector kit with tubing is supplied, see page B-49 for details and high pressure coolant fitting. For Turning inserts see Sect.A. For spare parts see page B-50.

**ADWLN R/L Toolholder Style L - Negative 5° end or side cutting lead angle for negative 80° trigon WNM\_ inserts**

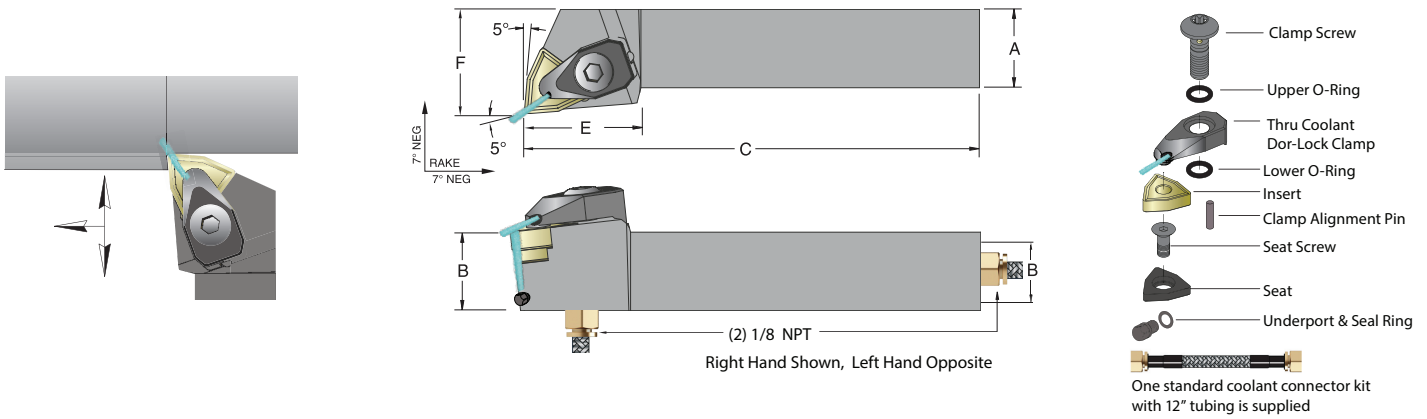

Metric Description	UPC No. 733101-		A	B	C	E	F	WNM_ Gage Insert	Seat	Seat Screw	Dor-Lock Clamp	Clamp Screw	Upper 'O' Ring	Lower 'O' Ring
	R.H.	L.H.												
ADWLNRL-2020-K06	52909	52910	20	20	125	25	25	060408	IWSN-322	SM-M4-245	JSLC-HPTW3R/L	JSCS-04	JSOR-01	JSOR-04
ADWLNRL-2020-K08	52911	52912	20	20	125	25	25	080408	IWSN-423	SM-S4	JSLC-HPTW4R/L	JSCS-04	JSOR-01	JSOR-04
ADWLNRL-2525-M06	52913	52914	25	25	150	25	32	060408	IWSN-322	SM-M4-245	JSLC-HPTW3R/L	JSCS-04	JSOR-01	JSOR-04
ADWLNRL-2525-M08	52915	52916	25	25	150	35	32	080408	IWSN-423	SM-S4	JSLC-HPTW4R/L	JSCS-04	JSOR-01	JSOR-04
ADWLNRL-3232-P08	52917	52918	32	32	170	35	40	080408	IWSN-423	SM-S4	JSLC-HPTW4R/L	JSCS-04	JSOR-01	JSOR-04
*ADWLNRL-4040-S08	52919	52920	40	40	250	35	50	080408	IWSN-423	SM-S4	JSLC-HPTW4R/L	JSCS-04	JSOR-01	JSOR-04

\*Special Order, available upon request. One standard coolant connector kit with tubing is supplied, see page B-49 for details and high pressure coolant fitting. For Turning inserts see Sect: A. For spare parts see page B-50.

**AS-ADCLN R/L Boring Bar Style L - Negative 5° side & end cutting lead angle for negative 80° diamond CNM\_ inserts**

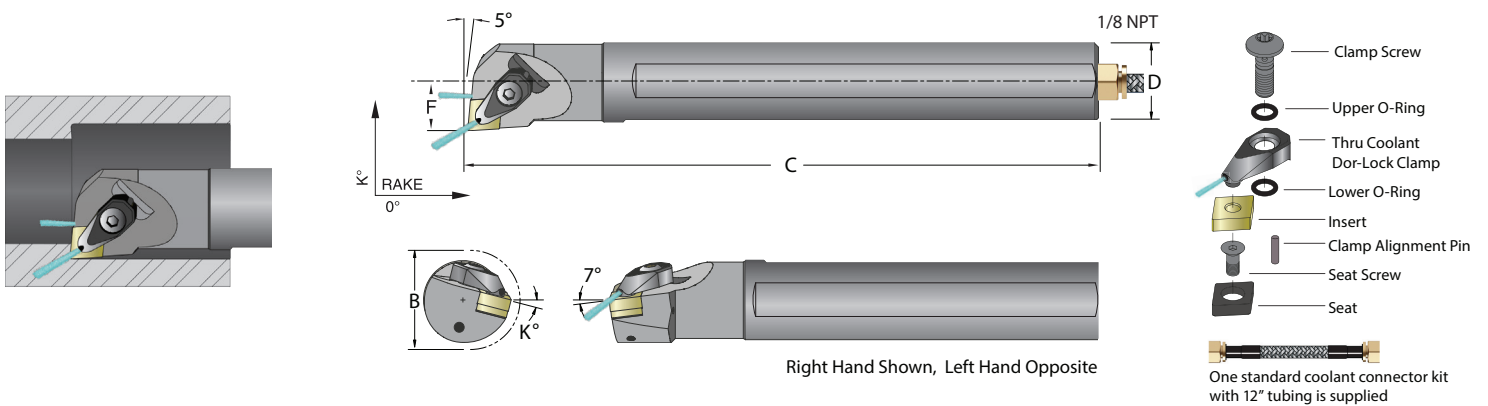

Metric Description	UPC No. 733101-		Min. Bore		C	D	F	K°	CNM_ Gage Insert	Seat	Seat Screw	Dor-Lock Clamp	Clamp Screw	Upper 'O' Ring	Lower 'O' Ring	Chip Flush Plug
	R.H.	L.H.	B	C												
AS-20R-ADCLNR/L-09	52925	52926	25	200	20	13	10°	090308	N/A	N/A	JSLC-HPCTW3-B	JSCS-03	JSOR-03	JSOR-06	JSPN-M3	
AS-25R-ADCLNR/L-12	52927	52928	32	200	25	17	14°	120408	JC-432	SM-S4	JSLC-HPCTW-4N	JSCS-04	JSOR-01	JSOR-04	JSPN-M6	
AS-32S-ADCLNR/L-12	52929	52930	40	250	32	22	14°	120408	JC-432	SM-S4	JSLC-HPCTW-4N	JSCS-04	JSOR-01	JSOR-04	JSPN-M6	
AS-40S-ADCLNR/L-12	52931	52932	45	250	40	27	11°	120408	JC-432	SM-S4	JSLC-HPCTW-4N	JSCS-04	JSOR-01	JSOR-04	JSPN-M6	
AS-50T-ADCLNR/L-12	52933	-	65	300	50	35	11°	120408	JC-432	SM-S4	JSLC-HPCTW-4N	JSCS-04	JSOR-01	JSOR-04	JSPN-M6	

One standard coolant connector kit with tubing is supplied, see page B-49 for details and high pressure coolant fitting. For Turning inserts see Sect:A. For spare parts see page B-50.

**AS-ADDPN R/L Boring Bar Style P- Negative 27.5° end cutting lead angle for negative 55° diamond DNM\_ inserts**

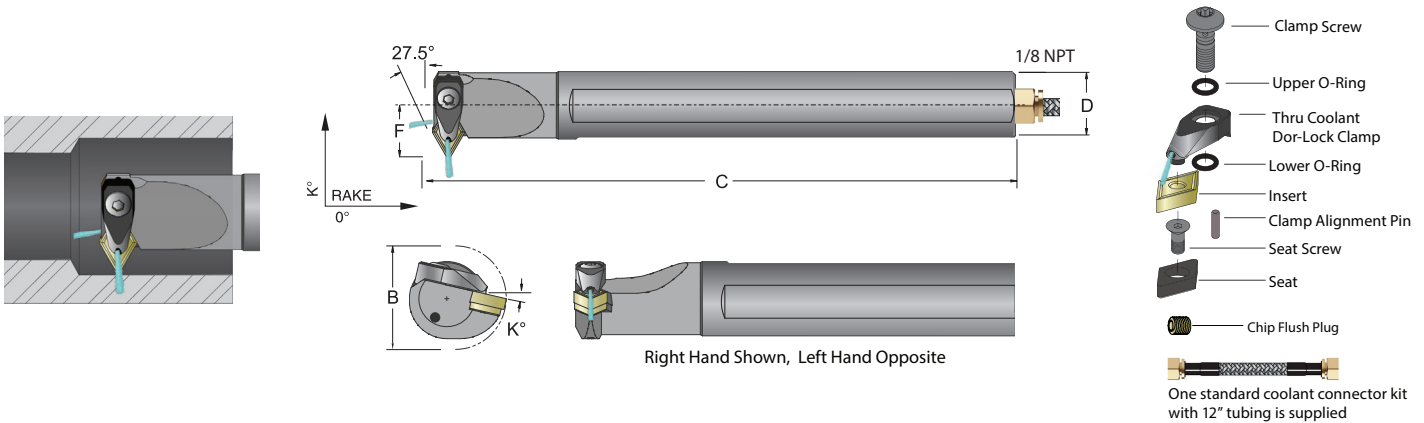

Metric Description	UPC No. 733101-		Min. Bore					DNM_		Seat Screw	Dor-Lock Clamp	Clamp Screw	Upper 'O' Ring	Lower 'O' Ring	Chip Flush Plug
	R.H.	L.H.	B	C	D	F	K°	Gage Insert	Seat						
AS-32S-ADDPNR/L-15	52939	-	39	250	32	19	13°	150608	IDSN-423	SM-S4	JSLC-HPD4	JSCS-04	JSOR-01	JSOR-04	JSPN-M6

One standard coolant connector kit with tubing is supplied, see page B-49 for details and high pressure coolant fitting. For Turning inserts see Sect: A. For spare parts see page B-50.

**AS-ADDUN R/L Boring Bar Style U - Negative 3° end cutting lead angle for negative 55° diamond DNM\_ inserts**

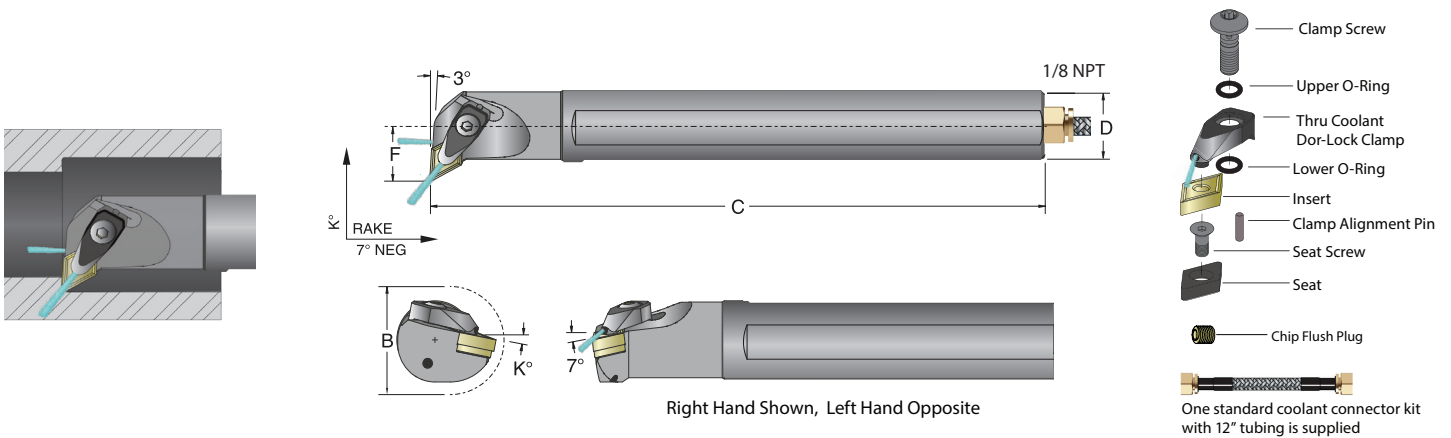

Metric Description	UPC No. 733101-		Min. Bore					DNM_		Seat Screw	Dor-Lock Clamp	Clamp Screw	Upper 'O' Ring	Lower 'O' Ring	Chip Flush Plug
	R.H.	L.H.	B	C	D	F	K°	Gage Insert	Seat						
AS-25R-ADDUNR/L-11	52946	52947	33	200	25	19	14°	110408	IDSN-322	SM-M4-245	JSLC-HPDT3R/L	JSCS-03	JSOR-03	JSOR-06	JSPN-M3
AS-32S-ADDUNR/L-15	52948	52949	50	250	32	25	11°	150608	IDSN-423	SM-S4	JSLC-HPD4	JSCS-04	JSOR-01	JSOR-04	JSPN-M6
AS-40S-ADDUNR/L-15	52950	-	57	250	40	28	11°	150608	IDSN-423	SM-S4	JSLC-HPD4	JSCS-04	JSOR-01	JSOR-04	JSPN-M6
AS-50T-ADDUNR/L-15	52952	52953	76	300	50	35	11°	150608	IDSN-423	SM-S4	JSLC-HPD4	JSCS-04	JSOR-01	JSOR-04	JSPN-M6

One standard coolant connector kit with tubing is supplied, see page B-49 for details and high pressure coolant fitting. For Turning inserts see Sect: A. For spare parts see page B-50. \*Right clamp for right hand toolholder. Left clamp for left hand toolholder

**AS-ADSKN R/L Boring Bar Style K - 15° End cutting lead angle for negative square SNM\_inserts**

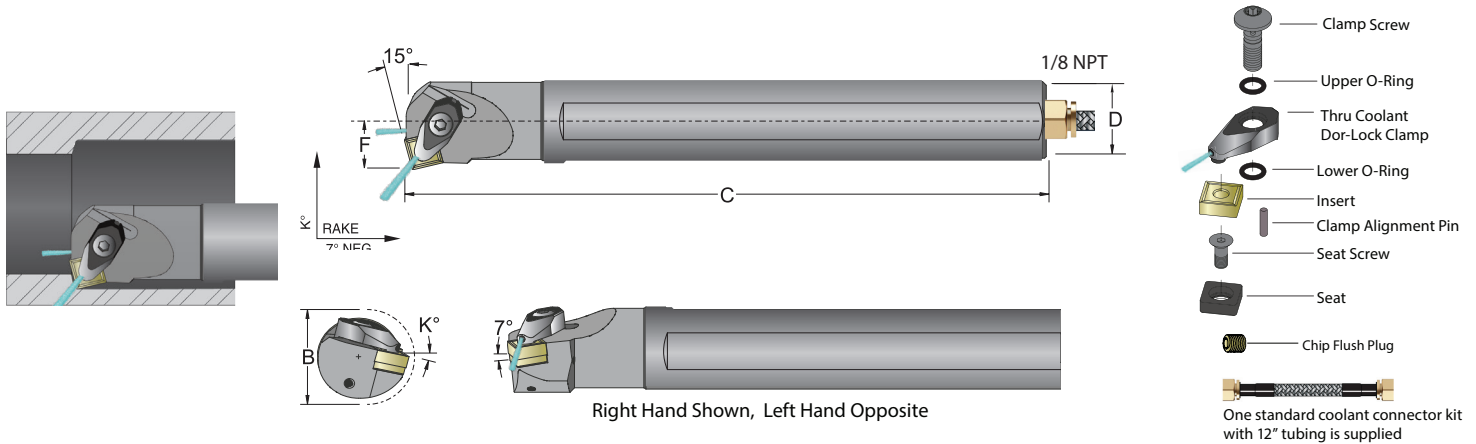

Metric Description	UPC No. 733101-		Min. Bore					SNM_ Gage Insert	Seat	Seat Screw	Dor-Lock Clamp	Clamp Screw	Upper 'O' Ring	Lower 'O' Ring	Chip Flush Plug
	R.H.	L.H.	B	C	D	F	K°								
AS-32S-ADSKNR/L-12	52958		45	250	32	19	10°	120408	ISSN-423	SM-S4	JSLC-HPCTW-4N	JSCS-04	JSOR-01	JSOR-04	JSPN-M6

One standard coolant connector kit with tubing is supplied, see page B-49 for details and high pressure coolant fitting. For Turning inserts see Sect: A. For spare parts see page B-50.

**AS-ADTUN R/L Boring Bar Style U - Negative 3° end cutting lead angle for negative triangle TNM\_inserts**

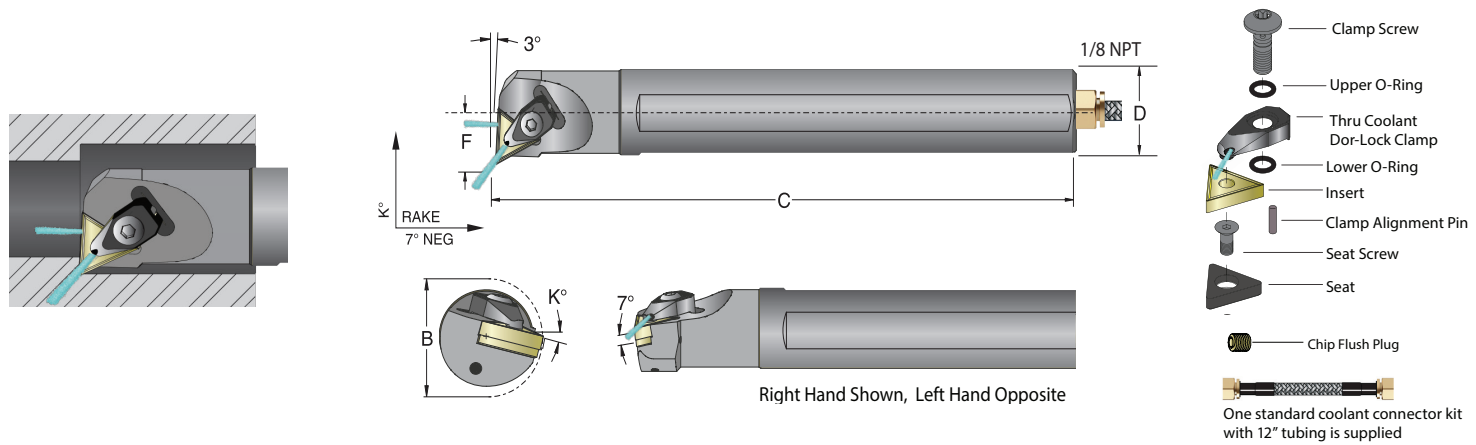

Metric Description	UPC No. 733101-		Min. Bore					TNM_ Gage Insert	Seat	Seat Screw	Dor-Lock Clamp	Clamp Screw	Upper 'O' Ring	Lower 'O' Ring	Chip Flush Plug
	R.H.	L.H.	B	C	D	F	K°								
AS-20R-ADTUNR/L-16	52967	52968	25	200	20	13	14°	160308	N/A	N/A	JSLCHPDT3R/L	JSCS-03	JSOR-03	JSOR-06	JSPN-M3
AS-25R-ADTUNR/L-16	52969	52970	33	200	25	17	14°	160408	JT-322	SM-M3-T	JSLC-HPDT3R/L	JSCS-03	JSOR-03	JSOR-06	JSPN-M3
AS-32S-ADTUNR/L-22	52971	-	39	250	32	20	14°	220408	JT-433	SM-S4	JSLC-HPTW4R/L	JSCS-04	JSOR-01	JSOR-04	JSPN-M6
AS-40S-ADTUNR/L-22	52973	-	53	250	40	22	11°	220408	JT-433	SM-S4	JSLC-HPTW4R/L	JSCS-04	JSOR-01	JSOR-04	JSPN-M6

One standard coolant connector kit with tubing is supplied, see page B-49 for details and high pressure coolant fitting. For Turning inserts see Sect: A. For spare parts see page B-50. Right clamp for right hand toolholder. Left clamp for left hand toolholder



**AS-ADVUN R/L Boring Bar Style U - Negative 3° side cutting lead angle for negative 35° diamond VNM\_ inserts**

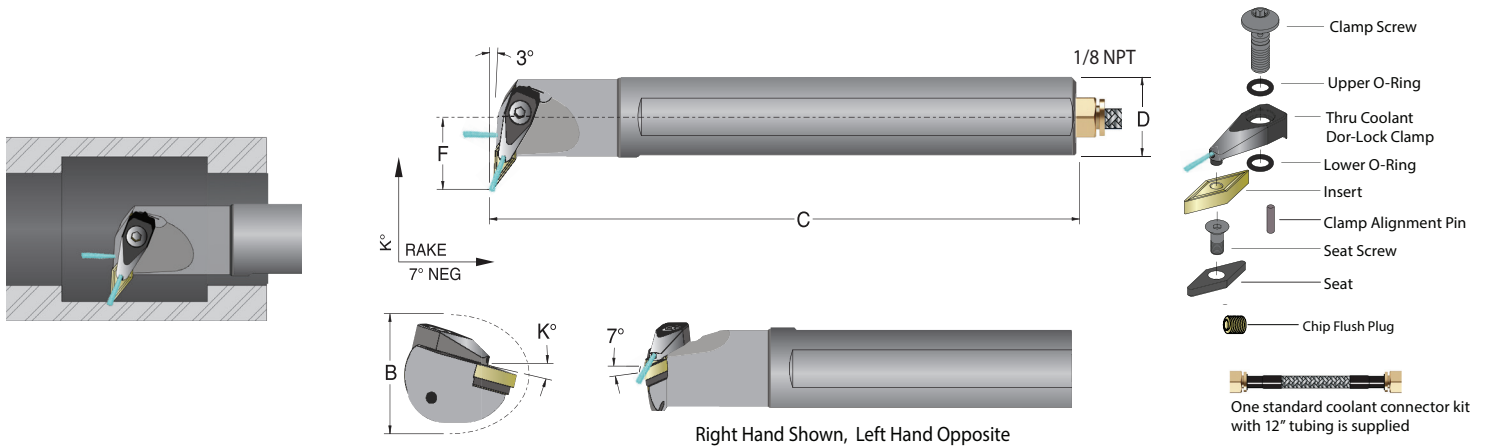

Metric Description	UPC No. 733101-		Min. Bore					VNM_		Seat Screw	Dor-Lock Clamp	Clamp Screw	Upper 'O' Ring	Lower 'O' Ring	Chip Flush Plug
	R.H.	L.H.	B	C	D	F	K°	Gage Insert	Seat						
AS-32R-ADVUNR/L-16	52980		58	200	32	28	14°	160408	JV-322	SM-M3	JSLC-HPV3	JSCS-04	JSOR-01	JSOR-04	JSPN-M6
AS-40S-ADVUNR/L-16	52982		64	250	40	32	11°	160408	JV-322	SM-M3	JSLC-HPV3	JSCS-04	JSOR-01	JSOR-04	JSPN-M6

One standard coolant connector kit with tubing is supplied, see page B-49 for details and high pressure coolant fitting. For Turning inserts see Sect: A. For spare parts see page B-50.

**AS-ADWLN R/L Boring Bar Style L - Negative 5° end & side cutting lead angle for negative 80° trigon WNM\_ inserts**

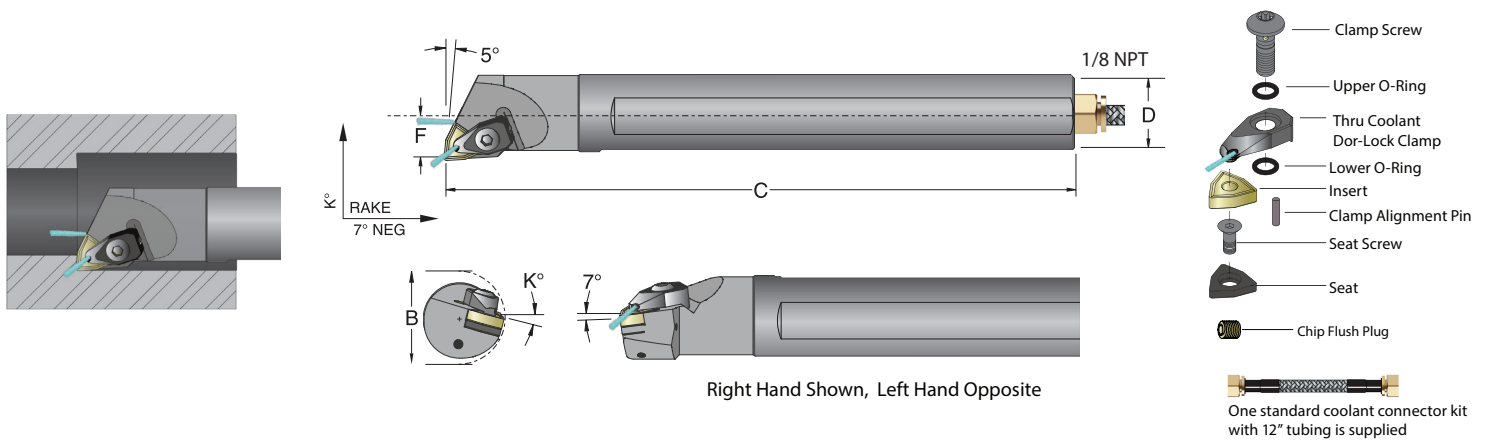

Metric Description	UPC No. 733101-		Min. Bore					WNM_		Seat Screw	Dor-Lock Clamp	Clamp Screw	Upper 'O' Ring	Lower 'O' Ring	Chip Flush Plug
	R.H.	L.H.	B	C	D	F	K°	Gage Insert	Seat						
AS-20R-ADWLNLR/L-06	52986	52987	26	200	20	13	14°	60408	N/A	N/A	*JSLC-HPW3-R/L	JSCS-03	JSOR-03	JSOR-06	JSPN-M3
AS-25R-ADWLNLR/L-08	52988	52989	33	200	25	17	14°	80408	IWSN-423	SM-S4	*JSLC-HPTW-4R/L	JSCS-04	JSOR-01	JSOR-04	JSPN-M6
AS-32S-ADWLNLR/L-08	52990	52991	38	250	32	22	14°	80408	IWSN-423	SM-S4	*JSLC-HPTW-4R/L	JSCS-04	JSOR-01	JSOR-04	JSPN-M6
AS-40S-ADWLNLR/L-08	52992	52993	46	250	40	27	11°	80408	IWSN-423	SM-S4	*JSLC-HPTW-4R/L	JSCS-04	JSOR-01	JSOR-04	JSPN-M6

One standard coolant connector kit with tubing is supplied, see page B-49 for details and high pressure coolant fitting. For Turning inserts see Sect: A. For spare parts see page B-50. \*Right clamp for right hand toolholder. Left clamp for left hand toolholder

**ADLE Qualified Laydown Threading Toolholder Style E - offset head for Laydown inserts**

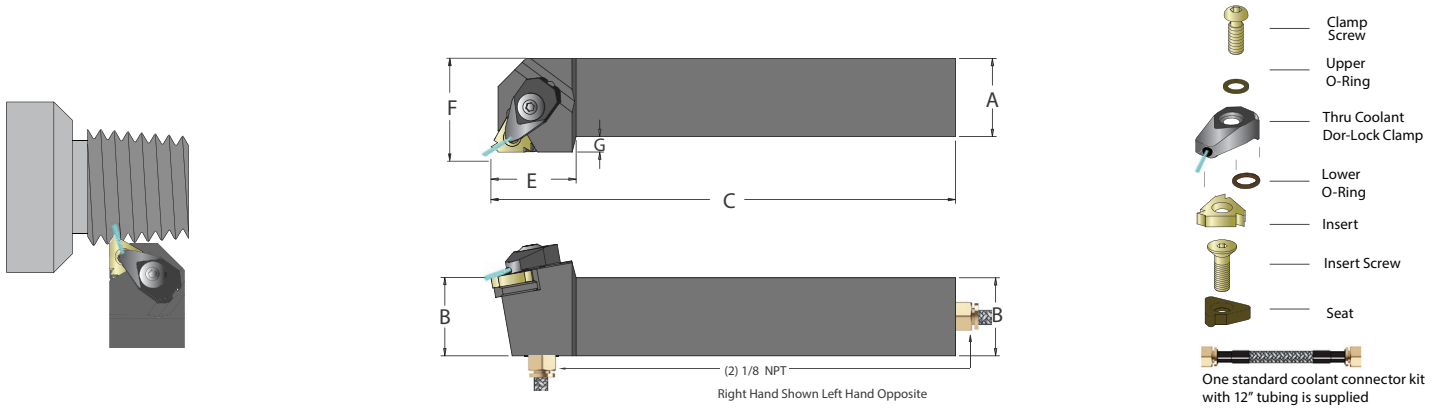

Metric Description	UPC No. 733101-		A	B	C	E	F	G	Gage	Insert	Insert	Dor-Lock	Clamp	Upper	Lower
	R.H.	L.H.							Insert	Seat	Screw	Clamp	'O' Ring	'O' Ring	
ADLER/L2020-16Q-K	53587	53588	20	20	125	32	25	5	16-G60	GXE/I-16	TS-35.6-14M1	*JSLC-HP16R-N	JSCS-03	JSOR-03	JSOR-06
ADLER/L2525-16Q-M	53589	53590	25	25	150	32	32	7				*JSLC-HP16L-N			
ADLER/L2525-22Q-M	53593	-	25	25	150	38	32	7	22-N60	NXE/I-22	TS-45.75-15M1	JSLC-HP22N	JSCS-04	JSOR-01	JSOR-04

One standard coolant connector kit with tubing is supplied, see page B-49 for details and high pressure coolant fitting. For Laydown inserts see pages E-20 - E-29. For spare parts see page B-50. \*Right hand toolholder use a left hand clamp and Left hand toolholder use a right hand clamp.

**AS-ADLN R/L Threading Bar Style N - Internal Laydown bar for Laydown threading**

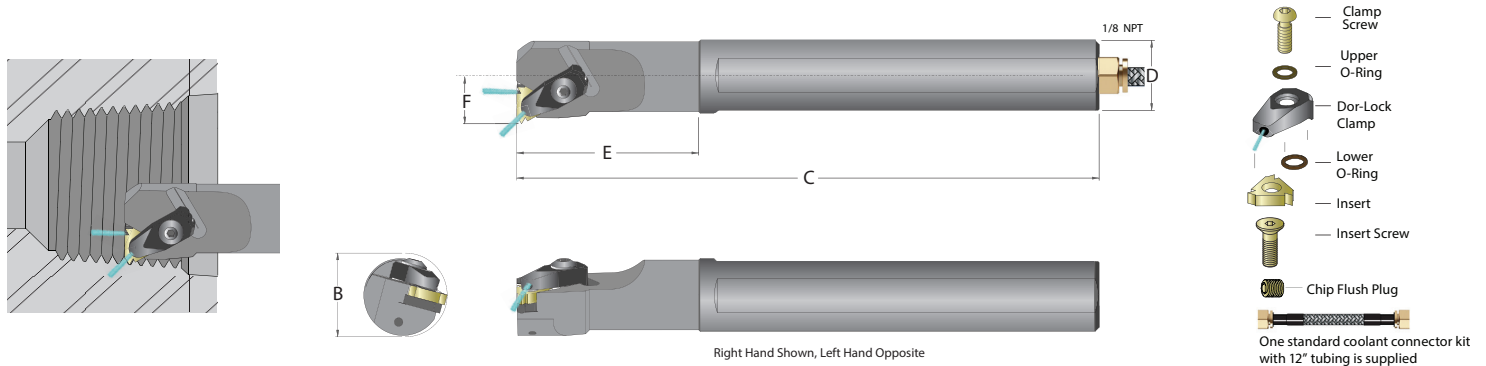

Metric Description	UPC No. 733101-		Min. Bore B	C	D	E	F	Gage	Insert	Insert	Dor-Lock	Clamp	Upper	Lower	Chip Flush
	R.H.	L.H.						Insert	Seat	Screw	Clamp	'O' Ring	'O' Ring	Plug	
AS-20R-ADLNR/L-16	53600	53601	28	200	20	51	13	16-G60	GXE/I-16	TS-35.6-14M1	*JSLC-HP16R-N	JSCS-03	JSOR-03	JSOR-06	JSPN-M3
AS-25R-ADLNR/L-16	53602	53603	35	200	25	64	17				*JSLC-HP16L-N				
AS-32S-ADLNR/L-16	53604	53605	41	250	32	64	19								
AS-40S-ADLNR/L-16	53606	53607	47	250	40	64	23								
AS-32S-ADLNR/L-22	-	53609	44	250	32	64	21	22-N60	NXE/I-22	TS-45.75-15M1	JSLC-HP22N	JSCS-04	JSOR-01	JSOR-04	JSPN-M6

One standard coolant connector kit with tubing is supplied, see page B-49 for details and high pressure coolant fitting. For Laydown inserts see pages E-20 - E-29. For spare parts see page B-50. \*Right hand toolholder use a left hand clamp and Left hand toolholder use a right hand clamp.

# API & Oil Field Jet-Stream™ Thru Coolant Threading Toolholders



**ADLE API Qualified Laydown Threading Toolholder Style E - offset head for Laydown inserts**

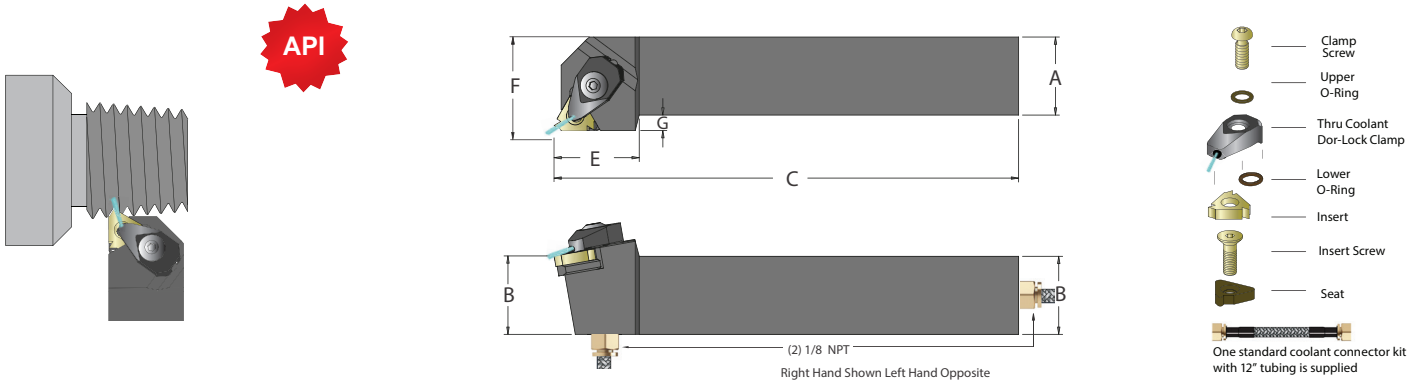

Inch Description	UPC No. 733101-R.H.	A	B	C	E	F	G	Gage Insert	Insert Seat	Insert Screw	Dor-Lock Clamp	Clamp Screw	Upper 'O' Ring	Lower 'O' Ring
								16-G60	GXE/I-16	TS-35.6-14M1	*JSLC-HP16R*N *JSLC-HP16L-N	JSCS-03	JSOR-03	JSOR-06
ADLER/L16-16Q-D	53524	1.00	1.00	6.00	1.25	1.25	0.25							
ADLER/L20-16Q-D	53526	1.25	1.25	6.00	1.25	1.50	0.25							

One standard coolant connector kit with tubing is supplied, see page B-49 for details and high pressure coolant fitting. For Turning inserts see Sect:A. For spare parts see page B-50.  
 \*Right hand toolholder use a left hand clamp and Left hand toolholder use a right hand clamp.

**AS-ADLN API Threading Bar Style N - Internal Laydown bar for Laydown threading inserts**

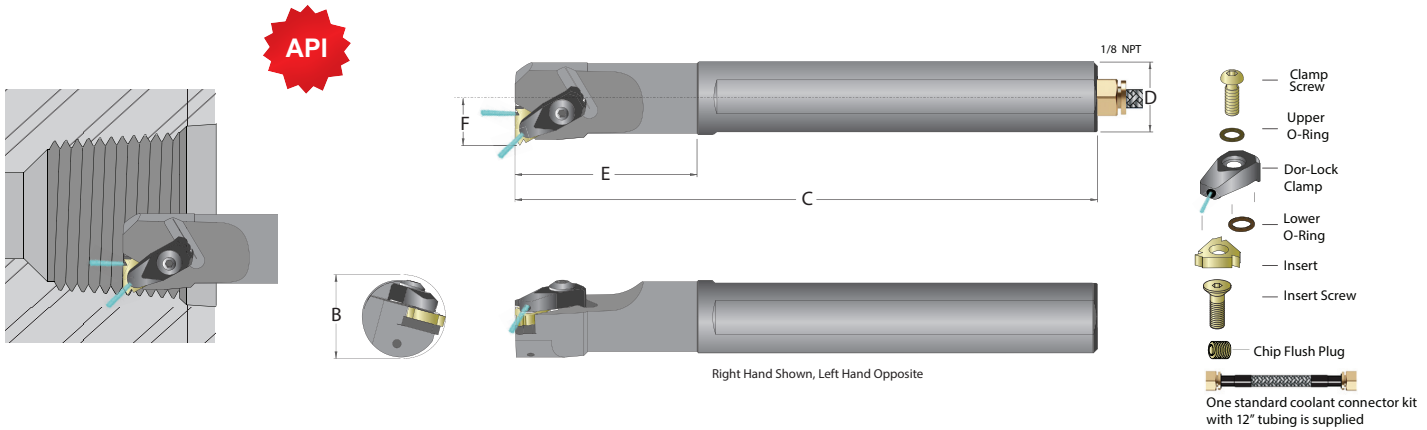

Inch Description	UPC No. 733101-R.H.	B	C	D	E	F	Gage Insert	Insert Seat	Insert Screw	Dor-Lock Clamp	Clamp Screw	Upper 'O' Ring	Lower 'O' Ring	Chip Flush Plug
							16-G60	GXE/I-16	TS-35.6-14M1	*JSLC-HP16R*N *JSLC-HP16L-N	JSCS-03	JSOR-03	JSOR-06	JSPN-M3
AS-24S-ADLNR/L-16	53539	1.87	10.00	1.50	2.50	.90								

One standard coolant connector kit with tubing is supplied, see page B-49 for details and high pressure coolant fitting. For Turning inserts see pages Sect: A.  
 For spare parts see page B-50. \*Right hand toolholder use a left hand clamp and Left hand toolholder use a right hand clamp.

**ADLE R/L API Toolholder Style E- External Laydown API Laydown toolholder for API Laydown inserts**

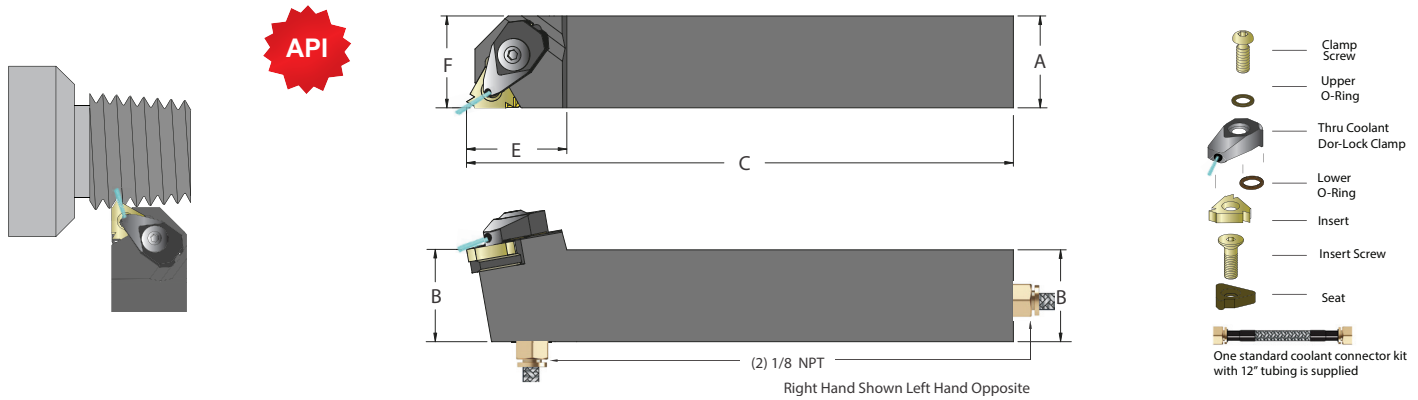

Inch Description	UPC No. 733101-		A	B	C	E	F	Gage		Insert Screw	Dor-Lock Clamp	Clamp Screw	Upper 'O' Ring	Lower 'O' Ring
	R.H.	L.H.						Insert	Seat					
ADLER/L20-T22API-D	53551	-	1.50	1.25	6.00	1.50	1.50	22-N60	NXE/I-22	TS-45.75-15M1	JSLC-HP22N	JSCS-04	JSOR-01	JSOR-04
ADLER/L24-T27API-F	53553	-	1.75	1.50	8.00	1.75	1.75	27-Q60	VXE/I-27	TS-5.8-22M1	JSLC-HP27N	JSCS-06	JSOR-07	JSOR-07

One standard coolant connector kit with tubing is supplied, see page B-49 for details and high pressure coolant fitting. For Turning inserts see Sect:A. For spare parts see page B-50.

**AS-ADLN R/L API Threading Bar Style N- Internal Laydown API Laydown toolholder for API Laydown inserts**

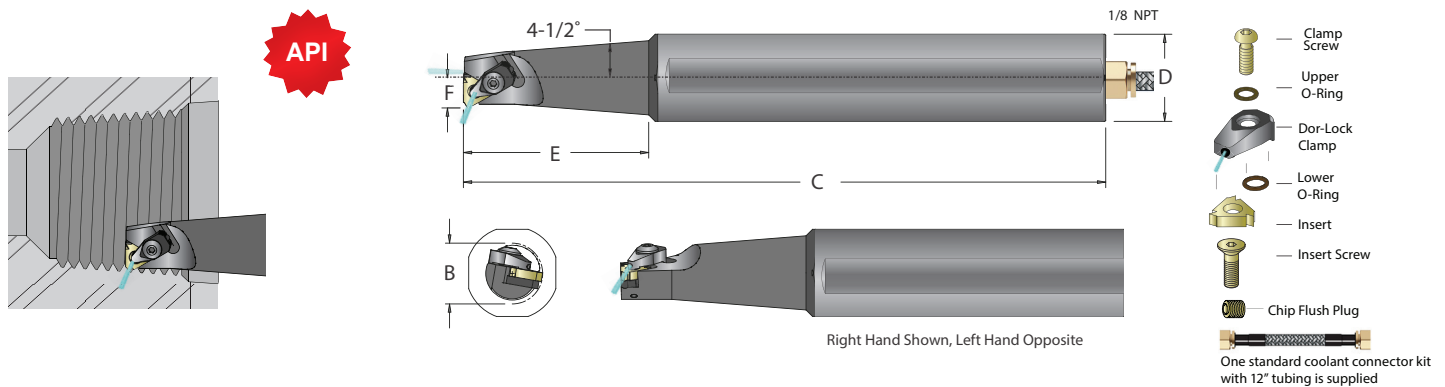

Inch Description	UPC No. 733101-		Min. Bore B	C	D	E	F	Gage		Insert Screw	Dor-Lock Clamp	Clamp Screw	Upper 'O' Ring	Lower 'O' Ring	Chip Flush Plug
	R.H.	L.H.						Insert	Seat						
AS-32T-ADLNR/L-22API	53559	53560	1.60	12.00	2.00	5.00	0.88	22-N60	NXE/I-22	TS-45.75-15M1	JSLC-HP22N	JSCS-04	JSOR-01	JSOR-04	JSPN-M6

One standard coolant connector kit with tubing is supplied, see page B-49 for details and high pressure coolant fitting. For Turning inserts see Sect: A. For spare parts see page B-50.



**AS-ADTHO API Threading Bar Style H - I.D. OnEdge Threading and shallow grooving for triangle TNMC inserts**

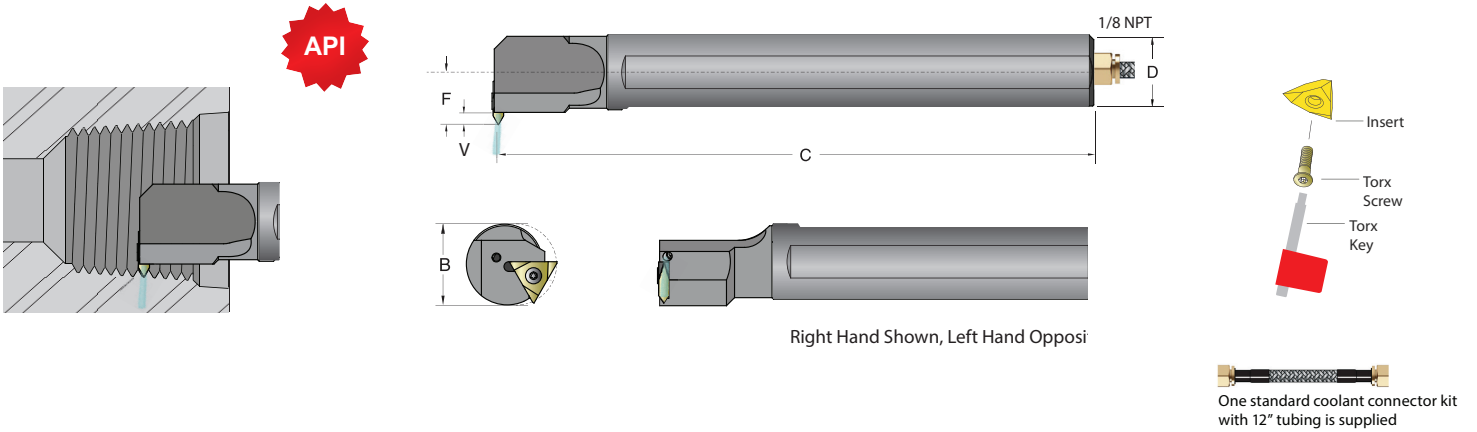

Inch Description	UPC No. 733101-R.H.	B	C	D	F	V	TNMC Gage Insert	Insert Torx Screw	Torx Key	Chip Flush Plug
AS-32T-ADTHOR-5	53444	3.000	12.00	2.00	1.380	0.25	543	GTS-3	T-20	JSPN-M6
AS-40T-ADTHOR-5	53446	3.750	12.00	2.50	1.690	0.25				

One standard coolant connector kit with tubing is supplied, see page B-49 for details and high pressure coolant fitting. For API OnEdge inserts see pages D-38-D-39. For spare parts see page B-50.

**ADNS API Toolholder Style S - External DorNotch toolholder for threading and grooving DorNotch inserts**

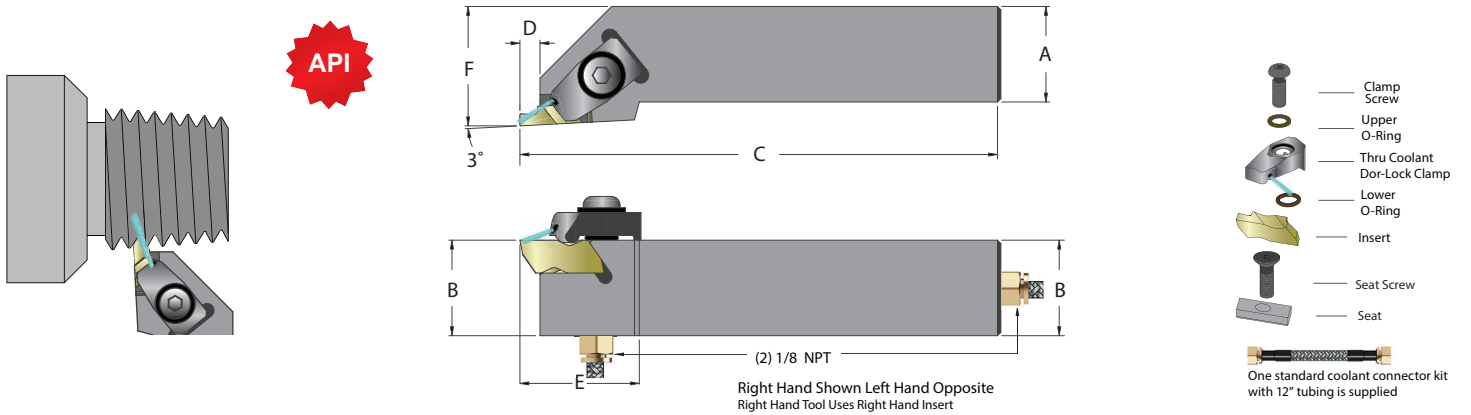

Inch Description	UPC No. 733101-R.H.	A	B	C	D	E	F	Gage Insert	Seat	Seat Screw	Dor-Lock Clamp	Clamp Screw	Upper 'O' Ring	Lower 'O' Ring
ADNSR16-3D	53452	1.00	1.00	6.00	0.21	1.25	1.25	* NG-3R	N/A	N/A	* JSLC-HP72	JSCS-04	JSOR-01	JSOR-04-DN
ADNSR20-3D	53454	1.25	1.25	6.00	0.21	1.25	1.50							
ADNSR16-4D	53456	1.00	1.00	6.00	0.29	1.38	1.25							
ADNSR20-4D	53458	1.25	1.25	6.00	0.29	1.38	1.50	* NG-4R	SM-420	SL-344	* JSLC-HP72	JSCS-04	JSOR-01	JSOR-04-DN

One standard coolant connector kit with tubing is supplied, see page B-49 for details and high pressure coolant fitting. For API DorNotch inserts see page D-46. For spare parts see page B-50.  
\*For right hand tool.

**AS-ADNE API Threading Bar Style E- Internal DorNotch Bar for threading and grooving DorNotch inserts**

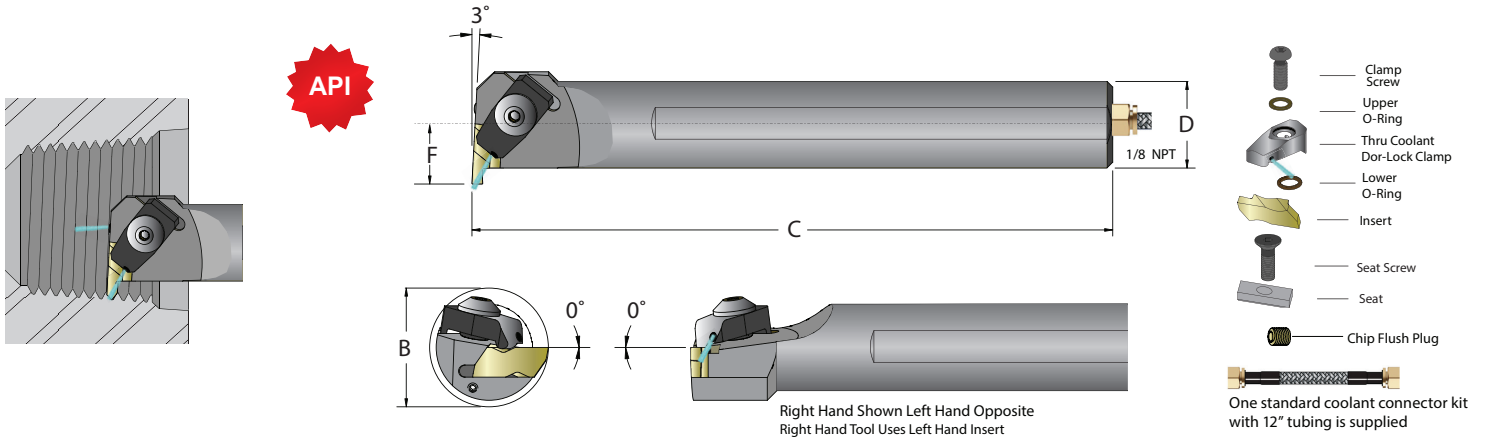

Inch Description	UPC No. 733101-R.H.	B	C	D	F	Gage Insert	Seat	Seat Screw	Dor-Lock Clamp	Clamp Screw	Upper 'O' Ring	Lower 'O' Ring	Chip Flush Plug
AS-16R-ADNER-3	53490	1.38	8.00	1.00	0.69								
AS-20S-ADNER-3	53492	1.75	10.00	1.25	0.88	* NG-3L ** NG-3R	N/A	N/A	* JSLC-HP73 ** JSLC-HP72	JSCS-04	JSOR-01	JSOR-04-DN	JSPN-M6
AS-24S-ADNER-3	53494	2.00	10.00	1.50	1.00								
AS-32T-ADNER-4	53496	2.75	12.00	2.00	1.38	* NG-4L ** NG-4R	N/A	N/A	* JSLC-HP73 ** JSLC-HP72	JSCS-04	JSOR-01	JSOR-04-DN	JSPN-M6

One standard coolant connector kit with tubing is supplied, see page B-49 for details and high pressure coolant fitting. For API DorNotch inserts see page D-46. For spare parts see page B-50.  
\*For right hand tool.

**ADLE API Qualified Laydown Threading Toolholder Style E - offset head for Laydown inserts**

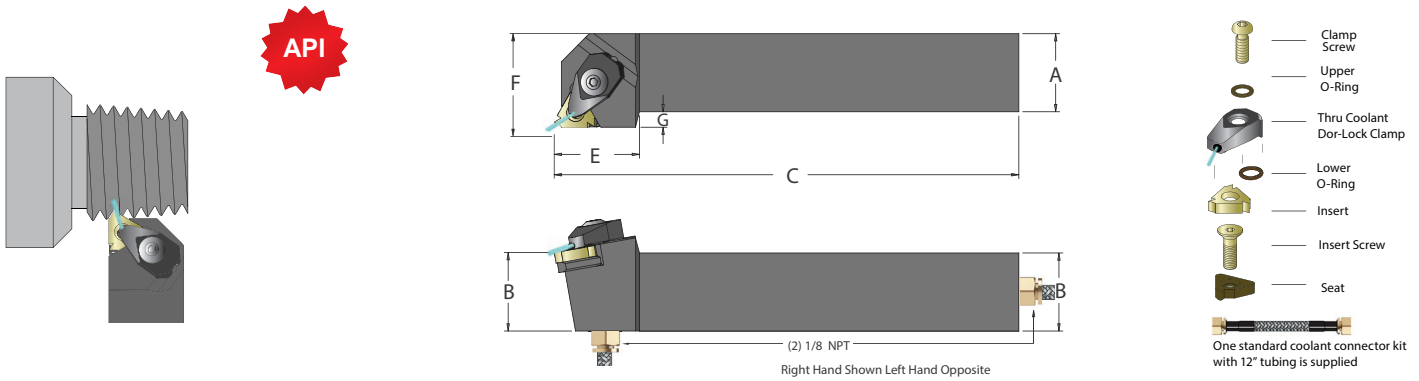

Metric Description	UPC No. 733101-R.H.	A	B	C	E	F	G	Gage	Seat	Seat Screw	Dor-Lock Clamp	Clamp Screw	Upper 'O' Ring	Lower 'O' Ring
								Insert						
ADLER2020-16Q-K	53587	20	20	125	32	25	5	16-G60	GXE/I-16	TS-35.6-14M1	*JSLC-HP16R-N *JSLC-HP16L-N	JSCS-03	JSOR-03	JSOR-06
ADLER2525-16Q-M	53589	25	25	150	32	32	7							

One standard coolant connector kit with tubing is supplied, see page B-49 for details and high pressure coolant fitting. For API Laydown inserts see pages D-40 - D-44. For spare parts see page B-50. \*Right hand toolholder use a left hand clamp and Left hand toolholder use a right hand clamp.

**AS-ADLN API Threading Bar Style N - Internal Laydown bar for Laydown threading**

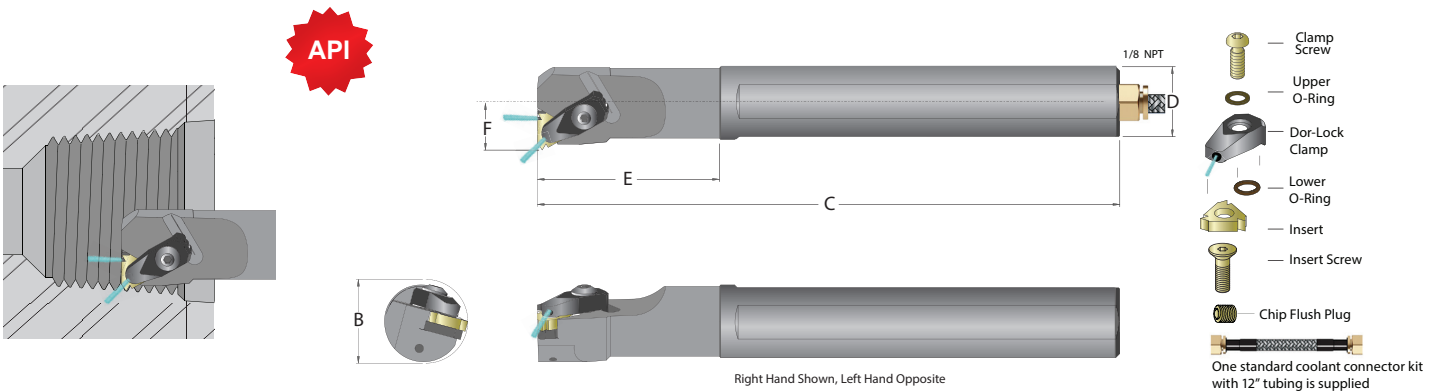

Metric Description	UPC No. 733101-R.H.	B	C	D	E	F	Gage	Seat	Seat Screw	Dor-Lock Clamp	Clamp Screw	Upper 'O' Ring	Lower 'O' Ring	Chip Flush Plug
							Insert							
AS-40S-ADLNR-16	53606	47	250	40	64	23	16-G60	GXE/I-16	TS-35.6-14M1	*JSLC-HP16R-N *JSLC-HP16L-N	JSCS-03	JSOR-03	JSOR-06	JSPN-M3

One standard coolant connector kit with tubing is supplied, see page B-49 for details and high pressure coolant fitting. For API Laydown inserts see pages D-40 - D-44. For spare parts see page B-50. \*Right hand toolholder use a left hand clamp and Left hand toolholder use a right hand clamp.

**Boring Bars and Tolholders-Low Pressure Coolant Connection 3 Pcs. Kit**

Working Pressure

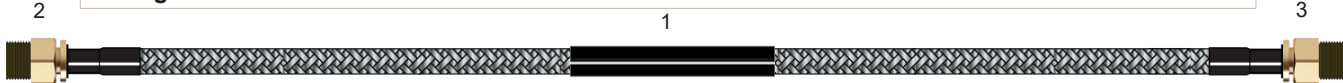

up to 400 psi (30 bar)

Item	Part Number	UPC No 733101-	Description	Bar	PSI
<b>JSPLPCK-062-250</b>					
1	JS-T250-1200	53349	1/4" OD, 12" Low High Pressure Long Tubing	30	400
2	JS-MC062-250	53346	1/16" NPT-1/4" Bore, Straight Low Pressure Quick Release Connector		
3	JS-MC125-250	53347	1/8" NPT-1/4" Bore, Straight Low Pressure Quick Release Connector		
<b>JSPLPCK-125-250</b>					
1	JS-T250-1200	53349	1/4" OD, 12" Low High Pressure Long Tubing	30	400
2	JS-MC125-250	53347	1/8" NPT-1/4" Bore, Straight Low Pressure Quick Release Connector		
3	JS-MC125-250	53347	1/8" NPT-1/4" Bore, Straight Low Pressure Quick Release Connector		
<b>JSPLPCK-250-250</b>					
1	JS-T250-1200	53349	1/4" OD, 12" Low High Pressure Long Tubing	30	400
2	JS-MC125-250	53347	1/8" NPT-1/4" Bore, Straight Low Pressure Quick Release Connector		
3	JS-MC250-250	53348	1/4" NPT-1/4" Bore, Straight Low Pressure Quick Release Connector		

**Boring Bars and Tolholders-High Pressure Coolant Connection 5 Pcs. Kit**

Working Pressure



over 400 psi (30 bar)



Item	Part Number	UPC No 733101-	Description	Bar	PSI
<b>DT-1/8 HP-QRCK</b>					
1	DT-HPTU-8X4	60477	8mm High Pressure 8mm Coolant Tubing Only	200	2800
2	DT-HP90C-1/8x6	60479	High Pressure Quick Release Straight Intec		
3	DT-HP90C-1/8x6	60479	High Pressure Quick Release Straight Intec		
4	DT-HP90C-1/8x6	60490	1/8" NPT Straight High Pressure Quick Release Connector		
5	DT-HP90C-1/8x6	60489	1/8" NPT 90° Elbow High Pressure Quick Release Connector		
<b>DT-1/4 HP-QRCK</b>					
1	DT-HPTU-8X4	60477	8mm High Pressure 8mm Coolant Tubing Only	200	2800
2	DT-HP90C-1/8x6	60479	High Pressure Quick Release Straight Intec		
3	DT-HP90C-1/8x6	60479	High Pressure Quick Release Straight Intec		
4	DT-HPOSC-1/4x6	60478	1/4" NPT Straight High Pressure Quick Release Connector		
5	DT-HP90C-1/8x6	60489	1/8" NPT 90° Elbow High Pressure Quick Release Connector		

Item	Part Number	UPC No 733101-	Description
	TD-HP-WRENCH	60076	High Pressure Disconnecting Player

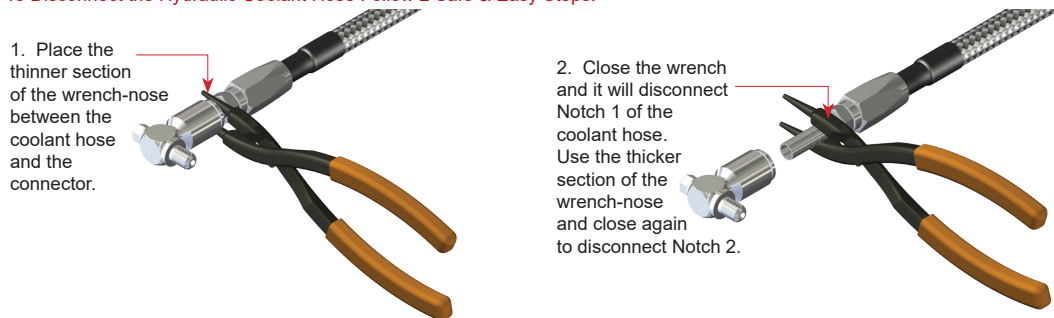
To Disconnect the Hydraulic Coolant Hose Follow 2 Safe & Easy Steps:



**Ball-Type Coolant Nozzles Sold Separately**

Acetal Material	Brass Material	Ball-Type Coolant Nozzles Size	Acetal Material		Brass Material	
			Desc.	UPC NO. 733101-	Desc.	UPC NO. 733101-
		12mm OD, 1/8NPT ID	JSCNA-12	53354	JSCNB-12	53365
		14mm OD, 1/8NPT ID	JSCNA-14	53355	JSCNB-14	53366
		15mm OD, 1/8NPT ID	JSCNA-15	53356	JSCNB-15	53367
		22mm OD, 1/8NPT ID	JSCNA-22	53357	JSCNB-22	53368
		1/2" OD, 1/8NPT ID	JSCNA-50	53358	JSCNB-50	53369
		5/8" OD, 1/8NPT ID	JSCNA-62	53359	JSCNB-62	53370

Note: For machines that have turrets with 1/8 NPT tapped coolant holes, you do not need a ball type coolant nozzle . Ball type coolant nozzles are sold separately.

## Jet-Stream™ Thru Coolant System Spare Parts

Image	Description	UPC No. 733101-
-------	-------------	--------------------

### Threading Insert (Laydown) Dor-Lock Clamp Sets\*

Image	Description	UPC No. 733101-
	JSLC-HP16R-N	53242
	JSLC-HP16L-N	53243
	JSLC-HP22N	53232
	JSLC-HP27N	53234



### Threading Insert (DorNotch) Dor-Lock Clamp Sets\*

Image	Description	UPC No. 733101-
	JSLC-HP72	53350
	JSLC-HP73	53351
	JSLC-HP76	53352
	JSLC-HP77	53353

### Turning Insert (CNMG & SNMG) Dor-Lock Clamp Sets\*

Image	Description	UPC No. 733101-
	JSLC-HPC3-B	53250
	JSLC-HPCTW-4N	53289
	JSLC-HPC5	53252
	JSLC-HPC6	53248

### Turning Insert (DNMG & TNMG) Dor-Lock Clamp Sets\*

Image	Description	UPC No. 733101-
	JSLC-HPD3	53253
	JSLC-HPD4	53254
	JSLC-HPDT3-BR	53268
	JSLC-HPDT3-BL	53029

### Turning Insert (TNMG & WNMG) Dor-Lock Clamp Sets\*

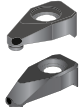
Image	Description	UPC No. 733101-
	JSLC-HPTW3N	53261
	JSLC-HPTW3R	53262
	JSLC-HPTW3L	53263
	JSLC-HPCTW-4N	53289
	JSLC-HPTW4R	53265
	JSLC-HPTW4L	53266
	JSLC-HPW3-B	53270

### Turning Insert (VNMG) Dor-Lock Clamp Sets\*

Image	Description	UPC No. 733101-
	JSLC-HPV3	53267

### NEW High Volume Turning Dor-Lock Clamp









Image	Description	UPC No. 733101-
	JSLC-HPCTW-4N-HPV	53290

Image	Description	UPC No. 733101-
-------	-------------	--------------------

### Jet-Stream™ Turning Shim Seats

Image	Description	UPC No. 733101-
	JC-432	90111
	JC-533	90112
	JC-633	90118
	IDSN-322	90016
	JD-432	90113
	IDSN-423	90118
	JV-322	90201
	JS-432	90114
	JS-533	90115
	ISSN-423	90056
		JT-322
JT-433		90116
IWSN-322		90070
	IWSN-423	90074
	IWSN-433	90072
		GXE/I-16
NXE/I-22		92071
VXE/I-27		92074
	SM-420	90400

### Insert Torx Screws/ Shim Screws





Image	Description	UPC No. 733101-
	GTS-1M	90964
	GTS-2	90966
	GTS-3	90967
	TS-35.6-9M1	90973
	TS-35.6-14M1	91303
	TS-45.75-15M1	91319
	TS-5.8-22M1	91302
	SL-344	91008
	SM-M3	53318
	SM-M3-T	53302
	SM-M6	53320
	SM-M66	53317
	SM-S4	53316
	SM-M4-245	53311

Image	Description	UPC No. 733101-
-------	-------------	--------------------

### Jet-Stream™ Clamp Screws

Image	Description	UPC No. 733101-
	JSCS-03	53323
	JSCS-04	53324
	JSCS-06	53326
	JSCS-04-HPV	53321

### Jet-Stream™ Clamp O Ring Seals

Image	Description	UPC No. 733101-
	JSOR-01	53315
	JSOR-03	53328
	JSOR-04	53314
	JSOR-06	53330
	JSOR-07	53327
	JSOR-08	53329
	JSOR-202	53335

### Jet-Stream™ Flush Nozzle/Plug

Image	Description	UPC No. 733101-
	JSPN-M3	53339
	JSPN-M6	53334
	JSFN-M6	53313

### Torx Keys

Image	Description	UPC No. 733101-
	T-10	92005
	T-20	92007

### Jet-Stream™ Clamp Alignment Pin

Image	Description	UPC No. 733101-
	JSCAP-01	53325

### Jet-Stream™ Underport Nozzle

Image	Description	UPC No. 733101-
	JSBP-M4-039	53244

### Jet-Stream™ Underport Seal

Image	Description	UPC No. 733101-
	JSBPS-M4-039	53245

\*Dor-Lock turning and threading *clamp sets* include *upper and lower o-rings*.